

OPERATOR'S MANUAL

 **AVCO** LYCOMING
O-320, IO-320
AIO-320 and LIO-320
SERIES
AIRCRAFT ENGINES

2nd. Edition

March, 1973

Approved by F.A.A.

Part No. 60297-16

Price \$5.00

 **AVCO** LYCOMING WILLIAMSPORT DIVISION
AVCO CORPORATION
WILLIAMSPORT, PENNSYLVANIA 17701

Printed in U. S. A.

TEXTRON Lycoming
OPERATOR'S MANUAL
REVISION

REVISION NO.	PUBLICATION	PUBLICATION NO.	PUBLICATION DATE
60297-16-4	O,IO,AIO,LIO-320 Operator's Manual	60297-16	March 1973
The page(s) in this revision replace, add to, or delete current pages in the operator's manual.			
PREVIOUS REVISIONS		CURRENT REVISIONS	
<p style="text-align: center;">January 1977</p> ii, 1-5; 2-5; Section 3 Index, 3-1, 3-2, 3-4, 3-6, 3-7, 3-8, 3-9, 3-10, 3-11, 3-12, 3-13, 3-14, 3-15, 3-16, 3-17, 3-18, 3-19, 3-20, 3-21, 3-22, 3-23, 3-24, 3-25, Added pages 3-26, 3-27; 5-5; 8-2		<p style="text-align: center;">April 1998</p> 3-3, 3-4, Adds page 3-4A/B	
<p style="text-align: center;">May 1980</p> 1-5; 2-2, 2-5; 3-9, 3-10, 3-11, Added pages 3-28, 3-29; 8-5			
<p style="text-align: center;">January 1993</p> Section 4 Index, 4-2, 4-3, 4-4, 4-5; 5-7, 5-8			



AVCO LYCOMING WILLIAMSPORT DIVISION

WARRANTY

RECIPROCATING AIRCRAFT ENGINE

WHAT AVCO LYCOMING PROMISES YOU

BASIC WARRANTY:

Avco Lycoming Williamsport Division, Avco Corporation (Avco Lycoming) warrants each new and remanufactured reciprocating aircraft engine and each new replacement part therefor, sold by it to be free from defects in material and workmanship appearing within 6 calendar months from the date of first operation, excluding necessary aircraft acceptance testing.

Avco Lycoming's obligation under this warranty shall be limited to its choice of repair or replacement, on an exchange basis, of the engine or any part of the engine or the replacement part, when Avco Lycoming has determined that the engine is defective in material or workmanship. You will be reimbursed for the charge for the engine or parts repaired or replaced. Avco Lycoming will also reimburse you for the costs for labor in connection with the repair or replacement as provided in Avco Lycoming's then current Removal and Installation Labor Allowance Guidebook.

Any engine or part installed during such repair or replacement will be warranted for the remainder of the basic warranty period.

PRORATION POLICY:

In addition, if Avco Lycoming determines that the engine proves to be defective in material or workmanship during the period until the expiration of Avco Lycoming's recommended Time Between Overhaul (TBO), or 3 years, whichever occurs first, Avco Lycoming will reimburse you for a pro rata portion (TBO minus hours of operation, divided by TBO) of the charge for the repair or replacement (at its choice) with Avco Lycoming parts, of parts required to be repaired or replaced, or a replacement engine, if it determines that engine replacement is required. Avco Lycoming's obligation during the proration period does not extend to accessories, including but not limited to magnetos, carburetors or fuel injectors, fuel pumps, starters, alternators and turbochargers and their controllers.

Any engine or part so repaired or replaced will be entitled to proration for the remainder of the original engine proration period.

YOUR OBLIGATIONS

The engine must have received normal use and service. You must make a warranty claim with an authorized Avco Lycoming distributor within 30 days of the appearance of the defect in material or workmanship.

Avco Lycoming's warranty does not cover normal maintenance expenses or consumable items. The obligations on the part of Avco Lycoming set forth above are your exclusive remedy and the exclusive liability of Avco Lycoming. This warranty allocates the risk of product failure between you and Avco Lycoming, as per-



mitted by applicable law.

Avco Lycoming reserves the right to deny any warranty claim if it reasonably determines that the engine or part has been subjected to accident or used, adjusted, altered, handled, maintained or stored other than as directed in your operator's manual.

Avco Lycoming may change the construction of engines at any time without incurring any obligation to incorporate such alterations in engines or parts previously sold.

THIS WARRANTY IS EXCLUSIVE AND IN LIEU OF ALL OTHER WARRANTIES AND REPRESENTATIONS, EXPRESS OR IMPLIED OR STATUTORY, WHETHER WRITTEN OR ORAL, INCLUDING BUT NOT LIMITED TO ANY WARRANTY OF MERCHANTABILITY OR FITNESS FOR ANY PARTICULAR PURPOSE, AND ANY IMPLIED WARRANTY ARISING FROM ANY COURSE OF PERFORMANCE OR DEALING OR TRADE USAGE. THIS WARRANTY IS ALSO IN LIEU OF ANY OTHER OBLIGATION, LIABILITY, RIGHT OR CLAIM, WHETHER IN CONTRACT OR IN TORT, INCLUDING ANY RIGHT IN STRICT LIABILITY IN TORT OR ANY RIGHT ARISING FROM NEGLIGENCE ON THE PART OF AVCO LYCOMING, AND AVCO LYCOMING'S LIABILITY ON SUCH CLAIM SHALL IN NO CASE EXCEED THE PRICE ALLOCABLE TO THE ENGINE OR PART WHICH GIVES RISE TO THE CLAIM.

LIMITATION OF LIABILITY

IN NO EVENT, WHETHER AS A RESULT OF A BREACH OF WARRANTY, CONTRACT OR ALLEGED NEGLIGENCE, SHALL AVCO LYCOMING BE LIABLE FOR SPECIAL OR CONSEQUENTIAL OR ANY OTHER DAMAGES, INCLUDING BUT NOT LIMITED TO LOSS OF PROFITS OR REVENUES, LOSS OF USE OF THE ENGINE OR COST OF A REPLACEMENT.

No agreement varying this warranty or Avco Lycoming's obligations under it will be binding upon Avco Lycoming unless in writing signed by a duly authorized representative of Avco Lycoming.

Effective June 14, 1985 Revision "D"

*Avco Lycoming Williamsport Division
Williamsport, Pennsylvania*



AVCO LYCOMING WILLIAMSPORT DIVISION

WARRANTY

REPLACEMENT PART - RECIPROCATING AIRCRAFT ENGINE

WHAT AVCO LYCOMING PROMISES YOU

BASIC WARRANTY:

Avco Lycoming Williamsport Division, Avco Corporation (Avco Lycoming) warrants each new reciprocating aircraft engine replacement part sold by it to be free from defects in material and workmanship appearing within 6 calendar months from its date of first operation.

Avco Lycoming's obligation under this warranty shall be limited to its choice of repair or replacement, on an exchange basis, of the replacement part, when Avco Lycoming has determined that the part is defective in material or workmanship. You will be reimbursed for the charge for the part or parts repaired or replaced. Avco Lycoming will also reimburse you for the costs for labor in connection with the repair or replacement as provided in Avco Lycoming's then current Removal and Installation Labor Allowance Guidebook.

Any part so repaired or replaced will be warranted for the remainder of the basic warranty period.

PRORATION POLICY:

In addition, for a period until the expiration of Avco Lycoming's recommended Time Between Overhaul (TBO), or 3 years, whichever occurs first, on the Avco Lycoming engine in which the replacement part is installed, Avco Lycoming will reimburse you for a pro rata portion (TBO minus hours of engine operation divided by TBO) of the charge for the repair or replacement with an Avco Lycoming part, of parts required to be repaired or replaced, if Avco Lycoming determines that the replacement part is defective in material or workmanship during the proration period. Avco Lycoming's obligation during the proration period does not extend to accessories, including but not limited to magnetos, carburetors or fuel injectors, fuel pumps, starters, alternators and turbochargers and their controllers.

Any part so repaired or replaced will be entitled to proration for the remainder of the original engine proration period.

YOUR OBLIGATIONS

The engine in which the replacement part is installed must have received normal use and service. You must make a warranty claim with an authorized Avco Lycoming distributor within 30 days of the appearance of the defect in material or workmanship.

Avco Lycoming's warranty does not cover normal maintenance expenses or consumable items. The obligations on the part of Avco Lycoming set forth above are your exclusive remedy and the exclusive liability of Avco Lycoming. This warranty allocates the risk of product failure between you and Avco Lycoming, as permitted by applicable law.

Avco Lycoming reserves the right to deny any warranty claim if it reasonably determines that the engine or part has been subjected to accident or used, adjusted, altered, handled, maintained or stored other than as



directed in your operator's manual.

Avco Lycoming may change the construction of its engines at any time without incurring any obligation to incorporate such alterations in engines or parts previously sold.

THIS WARRANTY IS EXCLUSIVE AND IN LIEU OF ALL OTHER WARRANTIES AND REPRESENTATIONS, EXPRESS OR IMPLIED OR STATUTORY, WHETHER WRITTEN OR ORAL, INCLUDING BUT NOT LIMITED TO ANY WARRANTY OF MERCHANTABILITY OR FITNESS FOR ANY PARTICULAR PURPOSE, AND ANY IMPLIED WARRANTY ARISING FROM ANY COURSE OF PERFORMANCE OR DEALING OR TRADE USAGE. THIS WARRANTY IS ALSO IN LIEU OF ANY OTHER OBLIGATION, LIABILITY, RIGHT OR CLAIM, WHETHER IN CONTRACT OR IN TORT, INCLUDING ANY RIGHT IN STRICT LIABILITY IN TORT OR ANY RIGHT ARISING FROM NEGLIGENCE ON THE PART OF AVCO LYCOMING, AND AVCO LYCOMING'S LIABILITY ON SUCH CLAIM SHALL IN NO CASE EXCEED THE PRICE ALLOCABLE TO THE ENGINE OR PART WHICH GIVES RISE TO THE CLAIM.

LIMITATION OF LIABILITY

IN NO EVENT, WHETHER AS A RESULT OF A BREACH OF WARRANTY, CONTRACT OR ALLEGED NEGLIGENCE, SHALL AVCO LYCOMING BE LIABLE FOR SPECIAL OR CONSEQUENTIAL OR ANY OTHER DAMAGES, INCLUDING BUT NOT LIMITED TO LOSS OF PROFITS OR REVENUES, LOSS OF USE OF THE ENGINE OR AIRCRAFT OR COST OF A REPLACEMENT.

No agreement varying this warranty or Avco Lycoming's obligations under it will be binding upon Avco Lycoming unless in writing signed by a duly authorized representative of Avco Lycoming.

Effective June 14, 1985 Revision "D"

*Avco Lycoming Williamsport Division
Williamsport, Pennsylvania*

ATTENTION

**OWNERS, OPERATORS, AND
MAINTENANCE PERSONNEL**

This operator's manual contains a description of the engine, its specifications, and detailed information on how to operate and maintain it. Such maintenance procedures that may be required in conjunction with periodic inspections are also included. This manual is intended for use by owners, pilots and maintenance personnel responsible for care of Avco Lycoming powered aircraft. Modifications and repair procedures are contained in Avco Lycoming overhaul manuals; maintenance personnel should refer to these for such procedures.

SAFETY WARNING

Neglecting to follow the operating instructions and to carry out periodic maintenance procedures can result in poor engine performance and power loss. Also, if power and speed limitations specified in this manual are exceeded, for any reason; damage to the engine and personal injury can happen. Consult your local FAA approved maintenance facility.

SERVICE BULLETINS, INSTRUCTIONS, AND LETTERS

Although the information contained in this manual is up-to-date at time of publication, users are urged to keep abreast of later information through Avco Lycoming Service Bulletins, Instructions and Service Letters which are available from all Avco Lycoming distributors or from the factory by subscription. Consult the latest edition of Service Letter No. L114 for subscription information.

SPECIAL NOTE

The illustrations, pictures and drawings shown in this publication are typical of the subject matter they portray; in no instance are they to be interpreted as examples of any specific engine, equipment or part thereof.

IMPORTANT SAFETY NOTICE

Proper service and repair is essential to increase the safe, reliable operation of all aircraft engines. The service procedures recommended by Avco Lycoming are effective methods for performing service operations. Some of these service operations require the use of tools specially designed for the task. These special tools must be used when and as recommended.

It is important to note that most Avco Lycoming publications contain various Warnings and Cautions which must be carefully read in order to minimize the risk of personal injury or the use of improper service methods that may damage the engine or render it unsafe.

It is also important to understand that these Warnings and Cautions are not all inclusive. Avco Lycoming could not possibly know, evaluate or advise the service trade of all conceivable ways in which service might be done or of the possible hazardous consequences that may be involved. Accordingly, anyone who uses a service procedure must first satisfy themselves thoroughly that neither their safety nor aircraft safety will be jeopardized by the service procedure they select.

TABLE OF CONTENTS

		Page
SECTION 1	DESCRIPTION	1-1
SECTION 2	SPECIFICATIONS	2-1
SECTION 3	OPERATING INSTRUCTIONS	3-1
SECTION 4	PERIODIC INSPECTIONS	4-1
SECTION 5	MAINTENANCE PROCEDURES	5-1
SECTION 6	TROUBLE—SHOOTING	6-1
SECTION 7	INSTALLATION AND STORAGE	7-1
SECTION 8	TABLES	8-1

INDEX OF ILLUSTRATIONS

Figure Number	Title	Page
	3/4 Left Front View - Typical O-320	viii
	Rear View - Typical IO-320-B Series	ix
	3/4 Left Rear View - Typical O-320	x
3-1	Graph, Effect of Fuel - Air Ratio on Cylinder Head Temperatures, etc.	3-14
3-2	Sea Level Power Curve - O-320-A, -E Series	3-15
3-3	Sea Level and Altitude Performance Curve - O-320-A, -E Series	3-16
3-4	Part Throttle Fuel Consumption Curve - O-320-A, -E Series	3-17
3-5	Sea Level Power Curve - O-320-B, -D Series	3-18
3-6	Sea Level and Altitude Performance Curve - O-320-B, -D Series	3-19
3-7	Part Throttle Fuel Consumption Curve - IO-320-A, -E Series	3-20
3-8	Sea Level and Altitude Performance Curve - IO-320-A Series	3-21
3-9	Sea Level and Altitude Performance Curve - IO-320-E Series	3-22
3-10	Part Throttle Fuel Consumption Curve - IO-320-B Series	3-23
3-11	Sea Level and Altitude Performance Curve - IO-320-B Series	3-24
3-12	Part Throttle Fuel Consumption Curve - IO-320-C Series	3-25
3-13	Sea Level and Altitude Performance Curve - IO-320-C Series	3-26
5-1	Ignition Wiring Diagram	5-2
5-2	Ignition Wiring Diagram (Optional)	5-3
5-3	Location of Shims Between Hold-Down Plates and Cylinder Barrel. Sequence of Tighten- ing Cylinder Hold-Down Nuts	5-12
7-1	Fuel Metering Systems	7-6

INDEX OF ILLUSTRATIONS (CONT.)

Figure Number	Title	Page
7-2	Fuel Metering Systems	7-7
7-3	Magneto Connections	7-8
7-4	Optional Oil Cooler Connections	7-9
7-5	Installation Drawing Left Side View - Typical O-320-A, -B Series	7-10
7-6	Installation Drawing Rear View - Typical O-320-A, -B Series	7-11
7-7	Installation Drawing Left Side View - Typical O-320-D, -E Series	7-12
7-8	Installation Drawing Rear View - Typical O-320-D, -E Series	7-13
7-9	Installation Drawing Left Side View - Typical IO-320-B Series	7-14
7-10	Installation Drawing Rear View - Typical IO-320-B Series	7-15

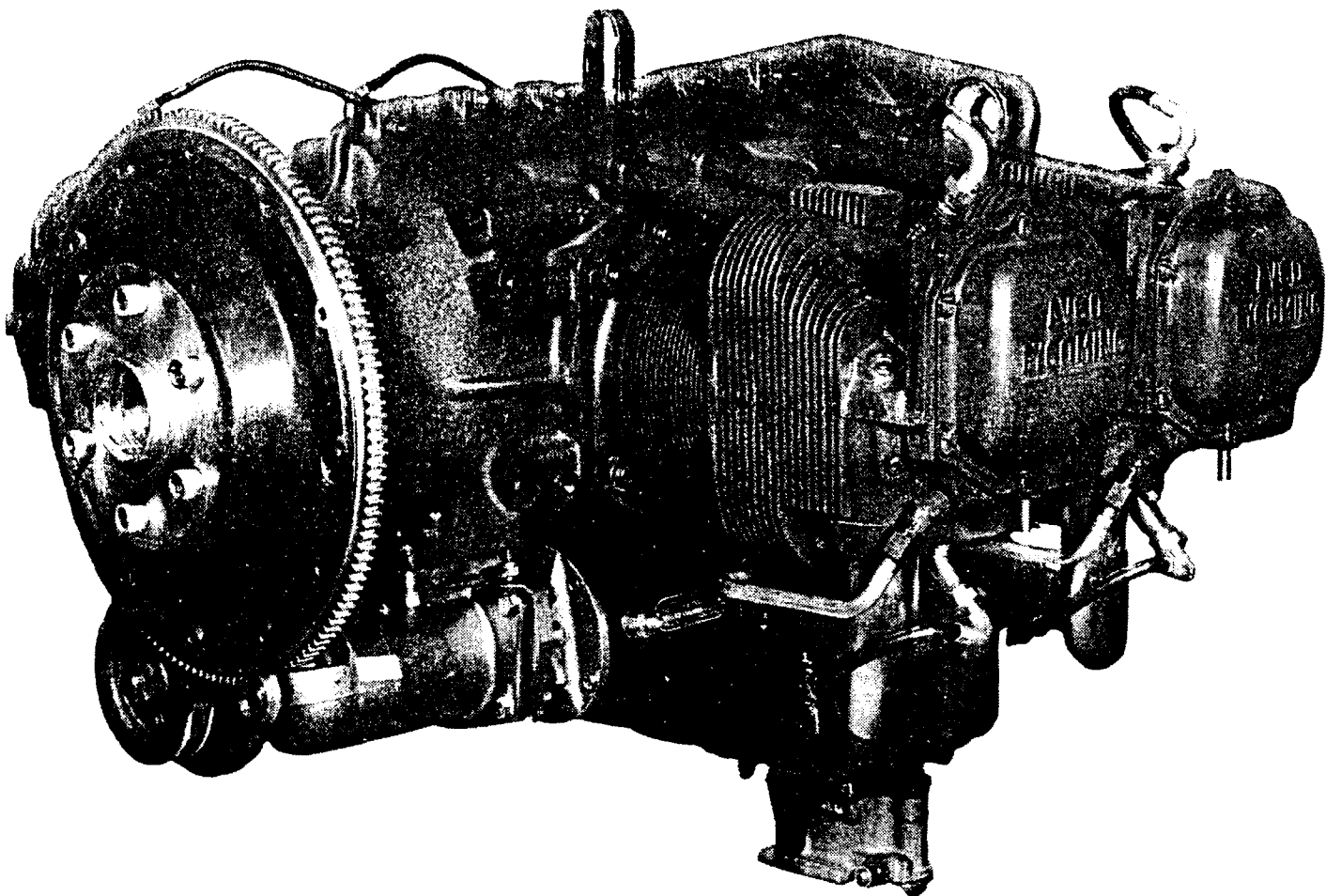

3/4 Left Front View - Typical O-320 Series

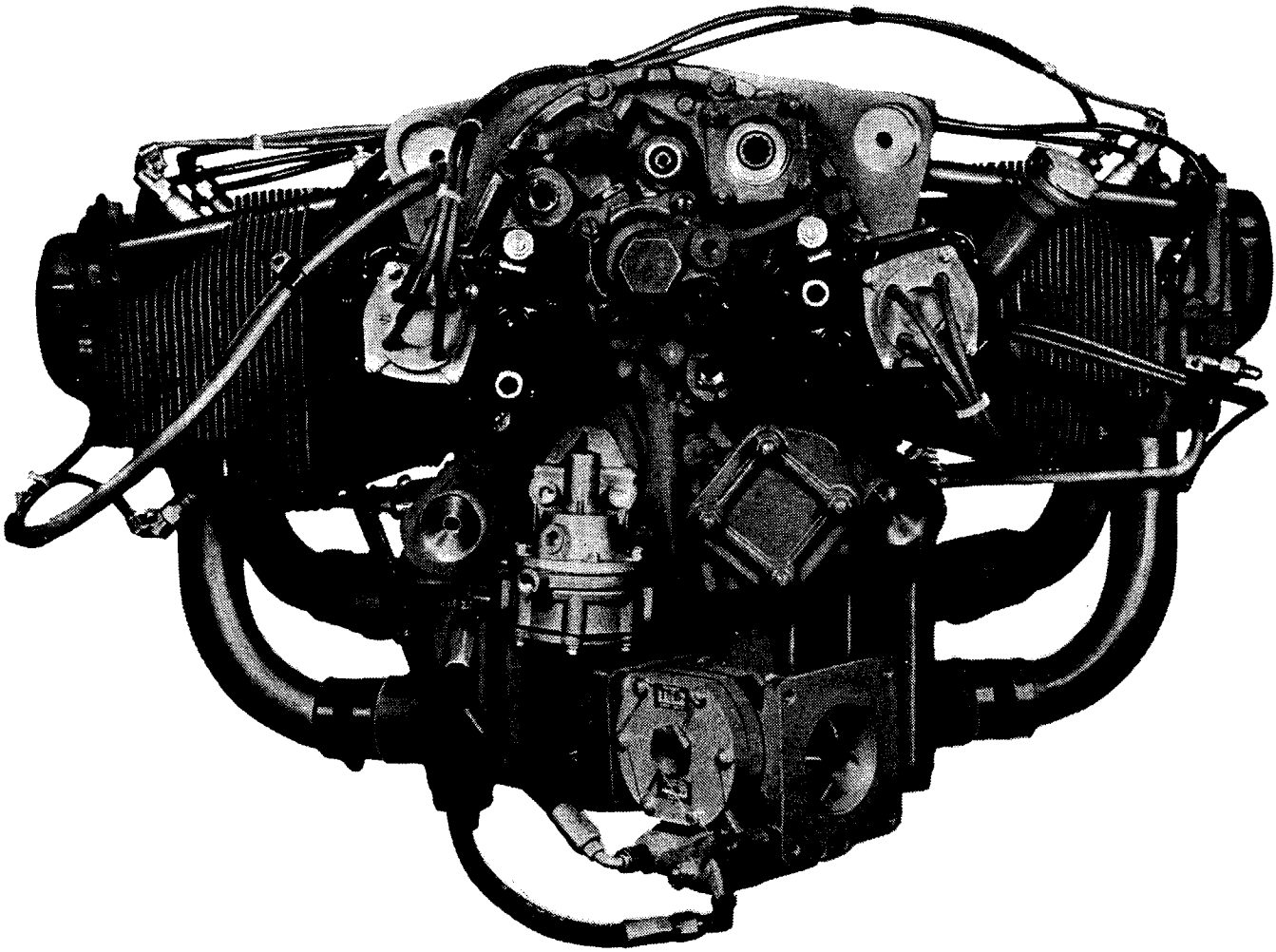

Rear View - Typical IO-320-B Series

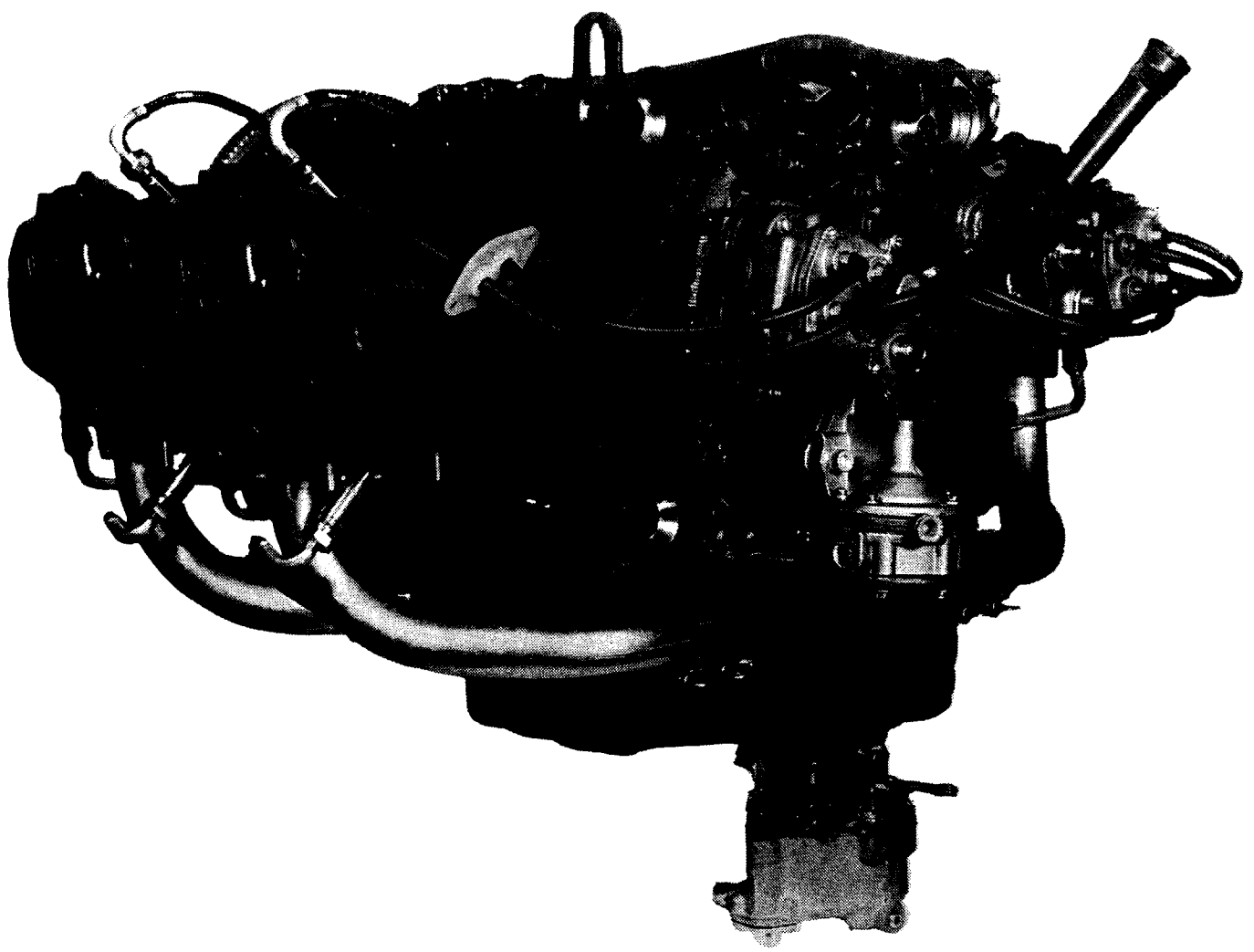

3/4 Left Rear View - Typical O-320 Series

SECTION

1

DESCRIPTION

DESCRIPTION

	Page
General1-1
Cylinders1-1
Valve Operating Mechanism1-1
Crankcase1-1
Crankshaft1-2
Connecting Rods1-2
Pistons1-2
Accessory Housing1-2
Oil Sump1-2
Cooling System1-2
Induction System1-2
Lubrication System1-3
Priming System1-4
Ignition System1-4
Model Application Table1-5

SECTION 1**DESCRIPTION**

The O, IO, AIO and LIO-320 series are four cylinder, direct drive, horizontally opposed, air cooled engines.

In referring to the location of the various engine components, the parts are described in their relationship to the engine as installed in the airframe. Thus, the power take-off end is considered the front and the accessory drive end the rear. The sump section is considered the bottom and the opposite side of the engine where the shroud tubes are located the top. Reference to the left and right side is made with the observer facing the rear of the engine. The cylinders are numbered from front to rear, odd numbers on the right, even numbers on the left. The direction of rotation for accessory drives is determined with the observer facing the drive pad. The direction of rotation of the crankshaft, viewed from the rear, is clockwise.

NOTE

The letter "L" in the model prefix denotes the reverse rotation of the basic model. Example: model IO-320-C has clockwise rotation of the crankshaft. Therefore, LIO-320-C has counter-clockwise rotation of the crankshaft. Likewise, the rotation of the accessory drives of the LIO-320-C are opposite those of the basic model as listed in Section 2 of this manual.

Operational aspects of both engines are the same and performance curves and specifications for the basic model will apply to the model with reverse rotation.

Cylinders - The cylinders are of conventional air cooled construction with the two major parts, head and barrel, screwed and shrunk together. The heads are made from an aluminum alloy casting with a fully machined combustion chamber. Rocker shaft bearing supports are cast integral with the head along with housings to form the rocker boxes for both valve rockers. The cylinder barrels, which are machined from chrome nickel molybdenum steel forgings, have deep integral cooling fins and the inside of the barrels are ground and honed to a specified finish.

AVCO LYCOMING OPERATOR'S MANUAL

SECTION 1

O-320 & IO-320 SERIES

Valve Operating Mechanism - A conventional type camshaft is located above and parallel to the crankshaft. The camshaft actuates hydraulic tappets which operate the valves through push rods and valve rockers. The valve rockers are supported on full floating steel shafts. The valve springs bear against hardened steel seats and are retained on the valve stems by means of split keys.

Crankcase - The crankcase assembly consists of two reinforced aluminum alloy castings, fastened together by means of studs, bolts and nuts. The mating surfaces of the two castings are joined without the use of a gasket, and the main bearing bores are machined for use of precision type main bearing inserts.

Crankshaft - The crankshaft is made from a chrome nickel molybdenum steel forging. All bearing journal surfaces are nitrided.

Connecting Rods - The connecting rods are made in the form of "H" sections from alloy steel forgings. They have replaceable bearing inserts in the crankshaft ends and bronze bushings in the piston ends. The bearing caps on the crankshaft ends are retained by two bolts and nuts through each cap.

Pistons - The pistons are machined from an aluminum alloy. The piston pin is of a full floating type with a plug located in each end of the pin. Depending on the cylinder assembly, pistons may employ either half wedge or full wedge rings. Consult the latest revision of Service Instruction No. 1037 for proper piston and ring combinations.

Accessory Housing - The accessory housing is made from an aluminum casting and is fastened to the rear of the crankcase and the top rear of the sump. It forms a housing for the oil pump and the various accessory drives.

Oil Sump (Except -AIO Series) - The sump incorporates an oil drain plug, oil suction screen, mounting pad for carburetor or fuel injector, the intake riser and intake pipe connections.

Crankcase Covers (-AIO Series) - Crankcase covers are employed on the top and bottom of the engine. These covers incorporate oil suction screens, oil scavenge line connections. The top cover incorporates a connection for a breather line and the lower cover a connection for an oil suction line.

Cooling System - These engines are designed to be cooled by air pressure. Baffles are provided to build up a pressure and force the air through the cylinder fins. The air is then exhausted to the atmosphere through gills or augmentor tubes usually located at the rear of the cowling.

Induction System - Avco Lycoming O-320 series engines are equipped with a float type carburetor. Particularly good distribution of the fuel - air mixture to each cylinder is obtained through the center zone induction system, which is integral with the oil sump and is submerged in oil, insuring a more uniform vaporization of fuel and aiding in cooling the oil in the sump. From the riser the fuel - air mixture is distributed to each cylinder by individual intake pipes.

Avco Lycoming IO-320 series engines are equipped with a Bendix type RSA fuel injector. The fuel injection system schedules fuel flow in proportion to air flow and fuel vaporization takes place at the intake ports.

A brief description of the carburetors and fuel injectors follows:

The Marvel-Schebler MA-4SPA and HA-6 carburetors are of the single barrel float type equipped with a manual mixture control and an idle-cut-off.

The Bendix RSA type fuel injection system is based on the principle of measuring air flow and using the air flow signal in a stem type regulator to convert the air force into a fuel force. This fuel force (fuel pressure differential) when applied across the fuel metering section (jetting system) makes fuel flow proportional to air flow. A manual mixture control and idle-cut-off are provided.

Lubrication System - The lubrication system is of the pressure wet sump type. The main bearings, connecting rod bearings, camshaft bearings, valve tappets, push rods and crankshaft idler gears are lubricated by means of oil collectors and spray. The oil pump, which is located in the accessory housing, draws oil through a drilled passage leading from the oil suction screen located in the sump. The oil from the pump then enters a drilled passage in the accessory housing, where a flexible line leads the oil to the external oil cooler. In the event that cold oil or an obstruction should restrict the flow of oil to the cooler, an oil cooler bypass valve is provided. Pressure oil from the cooler returns to a second threaded connection on the accessory housing from which point a drilled passage conducts the oil to the oil pressure screen, which is contained in a cast chamber located on the accessory housing below the tachometer drive.

SECTION 1**O-320 & IO-320 SERIES**

The oil pressure screen is provided to filter from the oil any solid particles that may have passed through the suction screen in the sump. After being filtered in the pressure screen chamber, the oil is fed through a drilled passage to the oil relief valve, located in the upper right side of the crankcase in front of the accessory housing.

This relief valve regulates the engine oil pressure by allowing excessive oil to return to the sump, while the balance of the pressure oil is fed to the main oil gallery in the right half of the crankcase. During its travel through this main gallery, the oil is distributed by means of separate drilled passages to the main bearings of the crankshaft. Separate passages from the rear main bearings supply pressure oil to both crankshaft idler gears. Angular holes are drilled through the main bearings to the rod journals. Oil from the main oil gallery also flows to the cam and valve gear passages, and is then conducted through branch passages to the hydraulic tappets and camshaft bearings. Oil enters the tappets through indexing holes and travels out through the hollow push rods to the valve mechanism, lubricating the valve rocker bearings and valve stems. Residual oil from the bearings, accessory drives and the rocker boxes is returned by gravity to the sump, where after passing through a screen it is again circulated through the engine. Pressure build up within the crankcase is held to a minimum by means of a breather located on the accessory housing.

In addition, model IO-320-C1A incorporates oil jets in the crankcase. The oil jets furnish an oil spray to provide internal cooling for the pistons.

Priming System - Provision for a primer system is provided on all engines employing a carburetor. Fuel injected engines do not require a priming system.

Ignition System - Dual ignition is furnished by two magnetos. Consult Table 1 for model application. Bendix magnetos are designed to permit periodic internal maintenance; Slick Electro magnetos are designed to operate for approximately 900 hours without internal maintenance.

AVCO LYCOMING OPERATOR'S MANUAL

0-320 & IO-320 SERIES

SECTION 1

MODEL APPLICATION					
Model	Left	Right	Height	Width	Length
0-320					
-A1A, -A1B	S4LN-21	S4LN-20	22.99	32.24	29.56
-A2A*, -A2B*	S4LN-21	S4LN-20	22.99	32.24	29.56
-A3A, -A3B	S4LN-21	S4LN-20	22.99	32.24	29.56
-A2C*, -A3C	S4LN-200	S4LN-204	22.99	32.24	29.81
-B1A, -B1B	S4LN-21	S4LN-20	22.99	32.24	29.56
-B2A*, -B2B*	S4LN-21	S4LN-20	22.99	32.24	29.56
-B3A, -B3B	S4LN-21	S4LN-20	22.99	32.24	29.56
-B2C*, -B3C	S4LN-200	S4LN-204	22.99	32.24	29.81
-D1A, -D2A*	S4LN-21	S4LN-20	22.99	32.24	29.56
-D1B, -D2B*	S4LN-200	S4LN-204	22.99	32.24	29.56
-D1C, -D2C*	S4LN-1227	S4LN-1209	22.99	32.24	30.70
-D1F, -D2F*	S4LN-1227	S4LN-1209	22.99	32.24	30.70
-E1A, -E2A*	S4LN-21	S4LN-20	22.99	32.24	29.56
-E1B, -E2B*	S4LN-200	S4LN-204	22.99	32.24	29.81
-E1C, -E2C*	S4LN-1227	S4LN-1209	22.99	32.24	30.70
-E1F, -E2F*	S4LN-1227	S4LN-1209	22.99	32.24	30.70
-E2D*, -E3D*	4051	4050	22.99	32.24	29.05
-A2D*, -E2G*	4051	4050	22.99	32.24	29.05
-D2G, -D3G	4051	4050	22.99	32.24	29.05
-E2H*, -E3H*	S4LN-21	S4LN-20	22.99	32.24	29.56
-D1D	4051	4050	19.22	32.24	31.82
-D2J*	4251	4251	23.00	32.24	29.05
IO-320					
-A1A, -A2A*	S4LN-200	S4LN-204	19.22	32.24	33.59
-B1A, -B2A*	S4LN-21	S4LN-20	19.22	32.24	33.59
-B1B	S4LN-21	S4LN-20	19.22	32.24	33.59
-B1C	S4LN-21	S4LN-20	19.22	32.24	32.09
-B1D	S4LN-1208	S4LN-1209	19.22	32.24	32.09
-C1A	S4LN-21	S4LN-21	19.22	32.24	33.59
-D1A, -D1B	S4LN-1227	S4LN-1209	23.18	32.24	30.70
-E2B*	4051	4050	23.18	32.24	29.05
-E1A, -E2A*	S4LN-21	S4LN-20	23.18	32.24	29.56

* - Fixed Pitch Propeller.

MODEL APPLICATION (CONT.)					
Model	Magnetos		Dimensions		
	Left	Right	Height	Width	Length
AIO-320					
-A1A, -A2A*	S4LN-1208	S4LN-1209	20.76	32.24	30.08
-A1B, -A2B*	S4LN-1227	S4LN-1209	20.76	32.24	30.08
-B1B	S4LN-1227	S4LN-1209	20.76	32.24	30.08
-C1B	S4LN-1227	S4LN-1209	25.57	32.24	30.08
LIO-320					
-B1A	S4RN-21	S4RN-20	19.22	32.24	33.59
-C1A	S4RN-21	S4RN-21	19.22	32.24	33.59

* - Fixed Pitch Propeller

SECTION

2

SPECIFICATION

SPECIFICATIONS

	Page
Explanatory Note2-1
Specifications - O-320-A, -B, -D, -E Series2-2
Specifications - IO-320-A, -B, -C, -D, -E Series; AIO-320; LIO-320 Series2-3
Accessory Drive Ratio2-4
Detail Weights2-5

**SECTION 2
SPECIFICATIONS**

The model specifications shown on the following pages of this section are divided according to model designation. When differences among models can be clearly stated, the specifications of more than one model are combined in a single group; otherwise, each model has its specifications listed separately. Also, as additional models are added to this series, new specification pages containing data pertinent to the new models will be added.

SPECIFICATIONS

0-320-A, -E* SERIES

FAA Type Certificate	274
Rated horsepower	150
Rated speed, RPM	2700
Bore, inches	5.125
Stroke, inches	3.875
Displacement, cubic inches	319.8
Compression ratio	7.0:1
Firing order	1-3-2-4
Spark occurs, degrees BTC	25
Valve rocker clearance (hydraulic tappets collapsed)	.028-.080
Propeller drive ratio	1:1
Propeller drive rotation (viewed from rear)	Clockwise

* - 0-320-E2A and -E2C have alternate rating of 140 HP at 2450 RPM.

SPECIFICATIONS

0-320-B, -D SERIES**

FAA Type Certificate	274
Rated horsepower	160
Rated speed, RPM	2700
Bore, inches	5.125
Stroke, inches	3.875
Displacement, cubic inches	319.8
Compression ratio	8.5:1
Firing order	1-3-2-4
Spark occurs, degrees BTC	25
Valve rocker clearance (hydraulic tappets collapsed)	.028-.080
Propeller drive ratio	1:1
Propeller drive rotation (viewed from rear)	Clockwise

** - 0-320-D2J has alternate rating of 150 HP at 2500 RPM and 155 HP at 2600 RPM.

SPECIFICATIONS

IO-320-A, -E SERIES

FAA Type Certificate	1E12
Rated horsepower	150
Rated speed, RPM	2700
Bore, inches	5.125
Stroke, inches	3.875
Displacement, cubic inches	319.8
Compression ratio	7.0:1
Firing order	1-3-2-4
Spark occurs, degrees BTC	25
Valve rocker clearance (hydraulic tappets collapsed)028-.080
Propeller drive ratio	1:1
Propeller drive rotation (viewed from rear)	Clockwise

SPECIFICATIONS

IO-320-B, -C, -D; AIO-320; LIO-320 SERIES

FAA Type Certificate	1E12
Rated horsepower	160
Rated speed, RPM	2700
Bore, inches	5.125
Stroke, inches	3.875
Displacement, cubic inches	319.8
Compression ratio	8.5:1
Firing order*	1-3-2-4
Spark occurs, degrees BTC	25
Valve rocker clearance (hydraulic tappets collapsed)028-.080
Propeller drive ratio	1:1
Propeller drive rotation (viewed from rear)	
All but LIO-320 Series	Clockwise
LIO-320 Series	Counter-Clockwise

* - LIO-320 Series Only - Firing Order 1-4-2-3

AVCO LYCOMING OPERATOR'S MANUAL**SECTION 2****O-320 & IO-320 SERIES**

*Accessory Drive	Drive Ratio	**Direction of Rotation
Starter	13.556:1	Counter-Clockwise
Starter	16.556:1	Counter-Clockwise
Generator	1.910:1	Clockwise
Generator	2.500:1	Clockwise
Alternator	3.250:1	Clockwise
Tachometer	0.500:1	Clockwise
Magneto	1.000:1	Clockwise
Vacuum Pump	1.300:1	Counter-Clockwise
Prop. Gov. AN20010		
Mounted on Accy. Hsg.	0.866:1	Clockwise
Mounted on Crankcase	0.895:1	Clockwise
Fuel Pump AN20003	1.000:1	Counter-Clockwise
Fuel Pump - Plunger operated	0.500:1	
Dual Drives		
Vac. - Hydraulic Pump	1.300:1	Counter-Clockwise
Vac. Pump - Prop. Gov.	1.300:1	Counter-Clockwise

* - When applicable.

** - Viewed facing drive pad.

NOTE that LIO-320 Series engines will have opposite rotation to the above.

DETAIL WEIGHTS

1. Engine, Standard, Dry Weight

Includes carburetor or fuel injector, magnetos, spark plugs, ignition harness, intercylinder baffles, tachometer drive, starter and generator (alternator) drive, starter and generator (alternator) with mounting bracket.

0-320-SERIES

-E2D, -E3D, -E2G	268 lbs.
-A1A, -A1B, -A2A, -A2B, -A3A, -A3B, -A2C	272 lbs.
-A3C, -E1A, -E2A, -E1B, -E2B, -E1C, -E2C	272 lbs.
-D2J	275 lbs.
-B2C, -B3C, -D1B, -D2B, -E1F, -E2F	277 lbs.
-B1A, -B1B, -B2A, -B2B, -B3A, -B3B	278 lbs.
-A2D, -D1A, -D1C, -D2A, -D2C	278 lbs.
-D2G, -D3G	281 lbs.
-D1D	283 lbs.
-D1F, -D2F	285 lbs.

IO-320 SERIES

-A1A, -A2A	280 lbs.
-B1B, -E1A, -E2A, -E2B	285 lbs.
-B1A, -B2A, -B1C, -B1D	287 lbs.
-D1A, -D1B	291 lbs.
-C1A	294 lbs.

AIO-320 SERIES

-A1A, -A2A	306 lbs.
-A1B, -A2B, -B1B, -C1B	307 lbs.

SECTION

3

**OPERATING
INSTRUCTIONS**

OPERATING INSTRUCTIONS

	Page
General	3-1
Prestarting Items of Maintenance	3-2
Starting Procedures	3-2
Cold Weather Starting	3-4
Ground Running and Warm-Up	3-4
Ground Check	3-4
Operation in Flight	3-5
Fuel Mixture Leaning Procedures	3-5
With EGT Gage	3-6
Without EGT Gage or Flowmeter	3-7
Alternate Method	3-7
Use of Carburetor Heat Control	3-8
Engine Flight Chart	3-10
Operating Conditions	3-10
Engine Shut Down	3-12
Performance Curves	3-14

SECTION 3

OPERATING INSTRUCTIONS

1. *GENERAL.* Close adherence to these instructions will greatly contribute to long life, economy and satisfactory operation of the engine.

NOTE

YOUR ATTENTION IS DIRECTED TO THE WARRANTIES THAT APPEAR IN THE FRONT OF THIS MANUAL REGARDING ENGINE SPEED, THE USE OF SPECIFIED FUELS AND LUBRICANTS, REPAIRS AND ALTERATIONS. PERHAPS NO OTHER ITEM OF ENGINE OPERATION AND MAINTENANCE CONTRIBUTES QUITE SO MUCH TO SATISFACTORY PERFORMANCE AND LONG LIFE AS THE CONSTANT USE OF CORRECT GRADES OF FUEL AND OIL, CORRECT ENGINE TIMING, AND FLYING THE AIRCRAFT AT ALL TIMES WITHIN THE SPEED AND POWER RANGE SPECIFIED FOR THE ENGINE. DO NOT FORGET THAT VIOLATION OF THE OPERATION AND MAINTENANCE SPECIFICATIONS FOR YOUR ENGINE WILL NOT ONLY VOID YOUR WARRANTY BUT WILL SHORTEN THE LIFE OF YOUR ENGINE AFTER ITS WARRANTY PERIOD HAS PASSED.

New engines have been carefully run-in by Avco Lycoming and therefore, no further break-in is necessary insofar as operation is concerned; however, new or newly overhauled engines should be operated on straight mineral oil for a minimum of 50 hours or until oil consumption has stabilized. After this period, a change to an approved additive oil may be made, if so desired.

NOTE

Cruising should be done at 65% to 75% power until a total of 50 hours has accumulated or oil consumption has stabilized. This is to ensure proper seating of the rings and is applicable to new engines, and engines in service following cylinder replacement or top overhaul of one or more cylinders.

The minimum fuel octane rating is listed in the flight chart, Part 10 of this section. Under no circumstances should fuel of a lower octane rating or automotive fuel (regardless of octane rating) be used.

LYCOMING OPERATOR'S MANUAL

SECTION 3

O-320 & IO-320 SERIES

2. *PRESTARTING ITEMS OF MAINTENANCE.* Before starting the aircraft engine for the first flight of the day, there are several items of maintenance inspection that should be performed. These are described in Section 4 under Daily Pre-Flight Inspection. They must be observed before the engine is started.

3. *STARTING PROCEDURES.*

The following starting procedures are recommended, however, the starting characteristics of various installations will necessitate some variation from these procedures.

NOTE

Cranking periods must be limited to ten (10) to twelve (12) seconds with a five (5) minute rest between cranking periods.

a. Carbureted Engines (Cold).

- (1) Perform pre-flight inspection.
- (2) Set carburetor heat control in "off" position.
- (3) Set propeller governor control in "Full RPM" position (where applicable).
- (4) Turn fuel valves "On".
- (5) Move mixture control to "Full Rich".
- (6) Turn on boost pump.
- (7) Open throttle approximately 1/4 travel.
- (8) Prime with 1 to 3 strokes of manual priming pump or activate electric primer for 1 or 2 seconds.
- (9) Set magneto selector switch (Consult airframe manufacturer's handbook for correct position).
- (10) Engage starter.
- (11) When engine fires move the magneto switch to "Both".
- (12) Check oil pressure gage. If minimum oil pressure is not indicated within thirty seconds, stop engine and determine trouble.

TEXTRON LYCOMING OPERATOR'S MANUAL

O-320 & IO-320 SERIES SECTION 3

NOTE

If engine fails to achieve a normal start, assume it to be flooded and use standard clearing procedure, then repeat above steps.

b. Carbureted Engines (Hot). Proceed as outlined above omitting the priming step.

c. Fuel Injected Engines (Cold).

- (1) Perform pre-flight inspection.
- (2) Set alternate air control in "off" position.
- (3) Set propeller governor control in "Full RPM" position (where applicable).
- (4) Turn fuel valve "On".
- (5) Turn boost pump "On".
- (6) Open throttle wide open, move mixture control to "Full Rich" until a slight but steady fuel flow is noted (approximately 3 to 5 seconds) then return throttle to "Closed" and return mixture control to "Idle Cut-Off".
- (7) Turn boost pump "Off".
- (8) Open throttle 1/4 of travel.
- (9) Set magneto selector switch. (Consult airframe manufacturer's handbook for correct position.)
- (10) Engage starter.
- (11) When engine fires move the magneto switch to "Both".
- (12) Move mixture control slowly and smoothly to "Full Rich".

TEXTRON LYCOMING OPERATOR'S MANUAL

SECTION 3

O-320 & IO-320 SERIES

(13) Check oil pressure gage. If minimum oil pressure is not indicated within thirty seconds, stop engine and determine trouble.

d. Fuel Injected Engines (Hot). Because of the fact that the fuel percolates and the system must be cleared of vapor, it is recommended that the same procedure be used as outlined for cold engine start.

4. *COLD WEATHER STARTING.* During extreme cold weather, it may be necessary to preheat the engine and oil before starting.

5. *GROUND RUNNING AND WARM-UP*

The engines covered in this manual are air-pressure cooled and depend on the forward speed of the aircraft to maintain proper cooling. Particular care is necessary, therefore, when operating these engines on the ground. To prevent overheating, it is recommended that the following precautions be observed.

NOTE

Any ground check that requires full throttle operation must be limited to three minutes, or less if the indicated cylinder head temperature should exceed the maximum stated in this manual.

- a. Head the aircraft into the wind.
- b. Leave mixture in "Full Rich".
- c. Operate only with the propeller in minimum blade angle setting.
- d. Warm-up at approximately 1000-1200 RPM. Avoid prolonged idling and do not exceed 2200 RPM on the ground.
- e. Engine is warm enough for take-off when the throttle can be opened without the engine faltering.

6. *GROUND CHECK.*

- a. Warm-up as directed above.

TEXTRON LYCOMING OPERATOR'S MANUAL

O-320 & IO-320 SERIES

SECTION 3

- b. Check both oil pressure and oil temperature.
- c. Leave mixture in "Full Rich".
- d. (Where applicable.) Move the propeller control through its complete range to check operation and return to full low pitch position. Full feathering check (twin engine) on the ground is not recommended but the feathering action can be checked by running the engine between 1000-1500 RPM; then momentarily pulling the propeller control into the feathering position. Do not allow the RPM to drop more than 500 RPM.
- e. A proper magneto check is important. Additional factors, other than the ignition system, affect magneto drop-off. They are load-power output, propeller pitch and mixture strength. The important thing is that the engine runs smoothly because magneto drop-off is affected by the variables listed above. Make the magneto check in accordance with the following procedures.

AVCO LYCOMING OPERATOR'S MANUAL

O-320 & IO-320 SERIES

SECTION 3

(1) (*Controllable Pitch Propeller*) With propeller in minimum pitch angle, set the engine to produce 50 - 65% power as indicated by the manifold pressure gage. Mixture control should be in the full rich position. At these settings, the ignition system and spark plugs must work harder because of the greater pressure within the cylinders. Under these conditions ignition problems, if they exist, will occur. Mag checks at low power settings will only indicate fuel-air distribution quality.

NOTE

Aircraft that are equipped with fixed pitch propellers, or not equipped with manifold pressure gage, may check magneto drop-off with engine operating at a maximum of 2000/2100 RPM.

(2) Switch from both magnetos to one and note drop-off, return to both until engine regains speed and switch to the other magneto and note drop-off, then return to both. Drop-off should not exceed 175 RPM and should not exceed 50 RPM between magnetos. A smooth drop-off past normal is usually a sign of a too lean or too rich mixture.

f. Do not operate on a single magneto for too long a period, a few seconds is usually sufficient to check drop-off and will minimize plug fouling.

7. OPERATION IN FLIGHT.

a. See airframe manufacturer's instructions for recommended power settings.

b. Fuel Mixture Leaning Procedure.

Improper fuel/air mixture during flight is responsible for many engine problems, particularly during take-off and climb power settings. The procedures described in this manual provide proper fuel/air mixture when leaning Avco Lycoming engines; they have proven to be both economical and practical by eliminating excessive fuel consumption and reducing damaged parts replacement. It is therefore recommended that operators, of all Avco Lycoming aircraft power-plants, utilize the instructions in this publication any time the fuel/air mixture is adjusted during flight.

LYCOMING OPERATOR'S MANUAL

SECTION 3

O-320 & IO-320 SERIES

Manual leaning may be monitored by exhaust gas temperature indication, fuel flow indication, and by observation of engine speed and/or airspeed. However, whatever instruments are used in monitoring the mixture, the following general rules should be observed by the operator of Avco Lycoming aircraft engines.

GENERAL RULES

Never exceed the maximum red line cylinder head temperature limit.

For maximum service life, cylinder head temperatures should be maintained below 435°F. (224°C.) during high performance cruise operation and below 400°F. (205°C.) for economy cruise powers.

Do not manually lean engines equipped with automatically controlled fuel system.

Maintain mixture control in "Full Rich" position for rated take-off, climb and maximum cruise powers (above approximately 75%). However, during take-off from high elevation airport or during climb, roughness or loss of power may result from over-richness. In such a case adjust mixture control only enough to obtain smooth operation - not for economy. Observe instruments for temperature rise. Rough operation due to over-rich fuel/air mixture is most likely to be encountered in carbureted engines at altitude above 5,000 feet.

Always return the mixture to full rich before increasing power settings.

Operate the engine at maximum power mixture for performance cruise powers and at best economy mixture for economy cruise power; unless otherwise specified in the airplane owners manual.

During let-down flight operations it may be necessary to manually lean uncompensated carbureted or fuel injected engines to obtain smooth operation.

1. LEANING TO EXHAUST GAS TEMPERATURE GAGE.

- a. Normally aspirated engines with fuel injectors or uncompensated carburetors.

AVCO LYCOMING OPERATOR'S MANUAL

O-320 & IO-320 SERIES

SECTION 3

(1) *Maximum Power Cruise (approximately 75% power)* - Never lean beyond 150°F. on rich side peak EGT unless aircraft operator's manual shows otherwise. Monitor cylinder head temperatures.

(2) *Best Economy Cruise (approximately 75% power and below)* - Operate at peak EGT, or if desired, drop 50°F. on rich side of peak EGT.

2. LEANING TO FLOWMETER.

Lean to applicable fuel-flow tables or lean to indicator marked for correct fuel-flow for each power setting.

3. LEANING WITH MANUAL MIXTURE CONTROL (Economy Cruise, 75% power or less) without flowmeter or EGT gage).

a. Carbureted Engines.

(1) Slowly move mixture control from "Full Rich" position toward lean position.

(2) Continue leaning until engine roughness is noted.

(3) Enrich until engine runs smoothly and power is regained.

b. Fuel Injected Engines.

(1) Slowly move mixture control from "Full Rich" position toward lean position.

(2) Continue leaning until slight loss of power is noted (loss of power may or may not be accomplished by roughness).

(3) Enrich until engine runs smoothly and power is regained.

As shown in Figure 3-1, if engine speed and throttle setting are kept constant at normal cruise conditions, the affect of leaning on engine power and engine temperatures will be as shown. Power drops rapidly when the engine is leaned beyond peak exhaust gas temperature; also, best power is attained on the rich side of peak exhaust gas temperature.

SECTION 3**O-320 & IO-320 SERIES**

9. *USE OF CARBURETOR HEAT CONTROL.* Under certain moist atmospheric conditions when the relative humidity is more than 50% and at temperature of 20° to 90°, it is possible for ice to form in the induction system, even in summer weather. This is due to the high air velocity through the carburetor venturi and the absorption of heat from this air by vaporization of the fuel. The temperature in the mixture chamber may drop as much as 70°F. below the temperature of the incoming air. If this air contains a large amount of moisture, the cooling process can cause precipitation in the form of ice. Ice formation generally begins in the vicinity of the butterfly and may build up to such an extent that a drop in power output could result. A loss of power is reflected by a drop in manifold pressure in installations equipped with constant speed propellers and a drop in manifold pressure and RPM in installations equipped with fixed pitch propellers. If not corrected, this condition may cause complete engine stoppage.

a. To avoid this, all installations are equipped with a system for preheating the incoming air supply to the carburetor. In this way sufficient heat is added to replace the heat loss of vaporization of fuel, preventing the mixture chamber temperature from dropping to the freezing point of water. This air preheater is essentially a tube or jacket through which the exhaust pipe from one or more cylinders is passed, and the air flowing over these surfaces is raised to the required temperature before entering the carburetor. Consistently high temperatures can cause a loss in power and a decided variation of mixture. The following outline is the proper method of utilizing the carburetor heat control.

(1) *Ground Operation* - Use of the carburetor air heat on the ground should be held to a minimum. On some installations the air does not pass through the air filter, and dirt and foreign substances can be taken into the engine with the resultant cylinder and piston ring wear. In dirt and dust free areas carburetor air heat should be used on the ground to make certain it is functioning properly, or when carburetor icing conditions require it.

(2) *Take-Off* - Take-offs and full throttle operation should be made with carburetor heat in full cold position. The possibility of throttle icing at wide throttle openings is very remote, so remote in fact, that it can be disregarded.

(3) *Climbing* - When climbing at part throttle power settings of 80% or above, the carburetor heat control should be set in the full cold position; however, if it is necessary to use carburetor heat to prevent icing it is possible for engine roughness to occur due to the over-rich fuel-air mixture produced by the additional carburetor heat. When this happens, carefully lean the mixture with the mixture control only enough to produce smooth engine operation. Do not continue to use carburetor heat after flight is out of icing conditions, and adjust mixture according to percent of power and altitude.

(4) *Flight Operation* - During normal flight, leave the carburetor air heat control in the cold position. On damp, cloudy, foggy or hazy days, regardless of the outside air temperatures, look out for loss of power. This will be evidenced by an unaccountable loss in manifold pressure or RPM or both, depending on whether a constant speed or fixed pitch propeller is installed on the aircraft. If this happens, apply full carburetor air heat and increase the throttle, if available to compensate for power loss. This will result in a slight additional drop in manifold pressure which is normal, and this drop will be regained as the ice is melted out of the induction system. When ice has been melted from the induction system, heat should be used as long as known or suspected icing exists. Only in those aircraft equipped with a carburetor air temperature gage may partial heat be used to keep the mixture temperature above freezing point (32°F.). Be alert to the threat of carburetor icing during reduced power operation on or above water.

WARNING

It is advisable, to use either full heat or no heat in aircraft that are not equipped with a carburetor air temperature gage. At an ambient temperature of 14°F. or below any mixture in the air is frozen and heat should not be used.

(5) *Landing Approach* - In making a landing approach, the carburetor heat should usually be in the "Full Cold" position. However, if icing conditions are known or suspected, the "Full Heat" should be applied. In the case that full power need be applied under these conditions, as for an aborted landing, the carburetor heat should be returned to "Full Cold" prior to full power application. See the aircraft flight manual for specific instructions. As a safety measure, there is no objection to the use of carburetor heat during landing approach provided that on a go-around, or touch-and-go landing, the carburetor heat is returned promptly to the cold position.



LYCOMING OPERATOR'S MANUAL

SECTION 3

0-320 & IO-320 SERIES

10. ENGINE FLIGHT CHART.

Fuel and Oil -

Model	Aviation Grade Fuel
0-320-A, -E Series	80/87 octane, minimum
IO-320-A, -E Series	80/87 octane, minimum
0-320-B, -D Series	91/96 or 100/130 octane, minimum
IO-320-B, -D Series	91/96 or 100/130 octane, minimum
IO-320-C Series	100/130 octane, minimum
AIO-320 Series	91/96 or 100/130 octane, minimum
LIO-320-B Series	91/96 or 100/130 octane, minimum
LIO-320-C Series	100/130 octane, minimum
0-320-D2J	100/100LL octane, minimum

NOTE: Aviation grade 100LL fuels in which the lead content is limited to 2 c.c. per gal. are approved for continuous use in the above listed engines.

ALL MODELS

Average Ambient Air	*Recommended Grade Oil	
	MIL-L-6082 Grades	Ashless Dispersant Grades
Above 80°F. (26.66°C.)	SAE 60	SAE 60
Above 60°F. (15.55°C.)	SAE 50	SAE 40 or SAE 50
30° (-1.11°C.) to 90°F. (32.22°C.)	SAE 40	SAE 40
0° (-17.77°C.) to 70°F. (21.11°C.)	SAE 20	SAE 30 or SAE 40
Below 10°F. (-12.22°C.)	SAE 20	SAE 30

* - Refer to the latest edition of Service Instruction No. 1014.

Oil Sump Capacity 8 U. S. Quarts

Minimum Safe Quantity in Sump 2 U. S. Quarts

OPERATING CONDITIONS

Average Ambient Air	Oil Inlet Temperature	
	Desired	Maximum
Above 80°F. (26.66°C.)	180°F. (82°C.)	245°F. (118°C.)
Above 60°F. (15.55°C.)	180°F. (82°C.)	245°F. (118°C.)
30° (-1.11°C.) to 90°F. (32.22°C.)	180°F. (82°C.)	245°F. (118°C.)
0° (-17.77°C.) to 70°F. (21.11°C.)	170°F. (77°C.)	225°F. (107°C.)
Below 10°F. (-12.22°C.)	160°F. (71°C.)	210°F. (99°C.)

Oil Pressure, psi	Maximum	Minimum	Idling
Normal Operating	90	60	25
Start and Warm-Up (except 0-320-D2J)	100		
0-320-D2J	115		

OPERATING CONDITIONS (CONT.)

Fuel Pressure, psi	Max.	Desired	Min.
0-320 Series			
Inlet to carburetor	8.0	3.0	0.5
IO-320-B, -D, -E Series; AIO-320; LIO-320-B			
Inlet to fuel pump	35	-----	-2
Inlet to fuel injector	45	-----	12
Inlet to fuel pump with injector in idle cut-off	55	-----	-----
IO-320-C Series; LIO-320-C			
Inlet to fuel pump	45	-----	-4
Inlet to fuel injector	45	-----	14
Inlet to fuel pump with injector in idle cut-off	55	-----	-----

Operation	RPM	HP	Fuel Cons. Gal./Hr.	Max. Oil Cons. Qts./Hr.	*Max. Cyl. Head Temp.
0-320-A, -E** Series					
Normal Rated	2700	150	-----	.67	500°F. (260°C.)
Performance Cruise (75% Rated)	2450	110	10.0	.37	500°F. (260°C.)
Economy Cruise (65% Rated)	2350	97	8.8	.33	500°F. (260°C.)
0-320-B, -D*** Series					
Normal Rated	2700	160	-----	.72	500°F. (260°C.)
Performance Cruise (75% Rated)	2450	120	10.0	.40	500°F. (260°C.)
Economy Cruise (65% Rated)	2350	104	8.8	.35	500°F. (260°C.)

* - At Bayonet Location - For maximum service life of the engine, maintain cylinder head temperatures between 150°F. (66°C.) and 435°F. (223.86°C.) during continuous operation.

** - 0-320-E2A and -E2C have alternate rating of 140 HP at 2450 RPM.

*** - 0-320-D2J has alternate 150 HP at 2500 RPM and 155 HP at 2600 RPM.

SECTION 3

O-320 & IO-320 SERIES

OPERATING CONDITIONS (CONT.)

Operation	RPM	HP	Fuel Cons. Gal./Hr.	Max. Oil Cons. Qts./Hr.	*Max. Cyl. Head Temp.
IO-320-A, -E Series					
Normal Rated	2700	150	-----	.67	500°F.
Performance Cruise (75% Rated)	2450	110	10.0	.37	500°F.
Economy Cruise (65% Rated)	2350	97	8.8	.33	500°F.
IO-320-B, -C, -D; AIO-320; LIO-320 Series					
Normal Rated	2700	160	-----	.72	500°F.
Performance Cruise (75% Rated)	2450	120	10.0	.40	500°F.
Economy Cruise (65% Rated)	2350	104	8.8	.35	500°F.

* - At Bayonet Location - For maximum service life of the engine, maintain cylinder head temperatures between 150°F. and 435°F. during continuous operation.

11. ENGINE SHUT-DOWN.

- a. Set propeller at minimum blade angle (where applicable).
- b. Idle until there is a decided decrease in cylinder head temperature.
- c. Move mixture control to "Idle Cut-Off".
- d. When engine stops, turn ignition switch off.

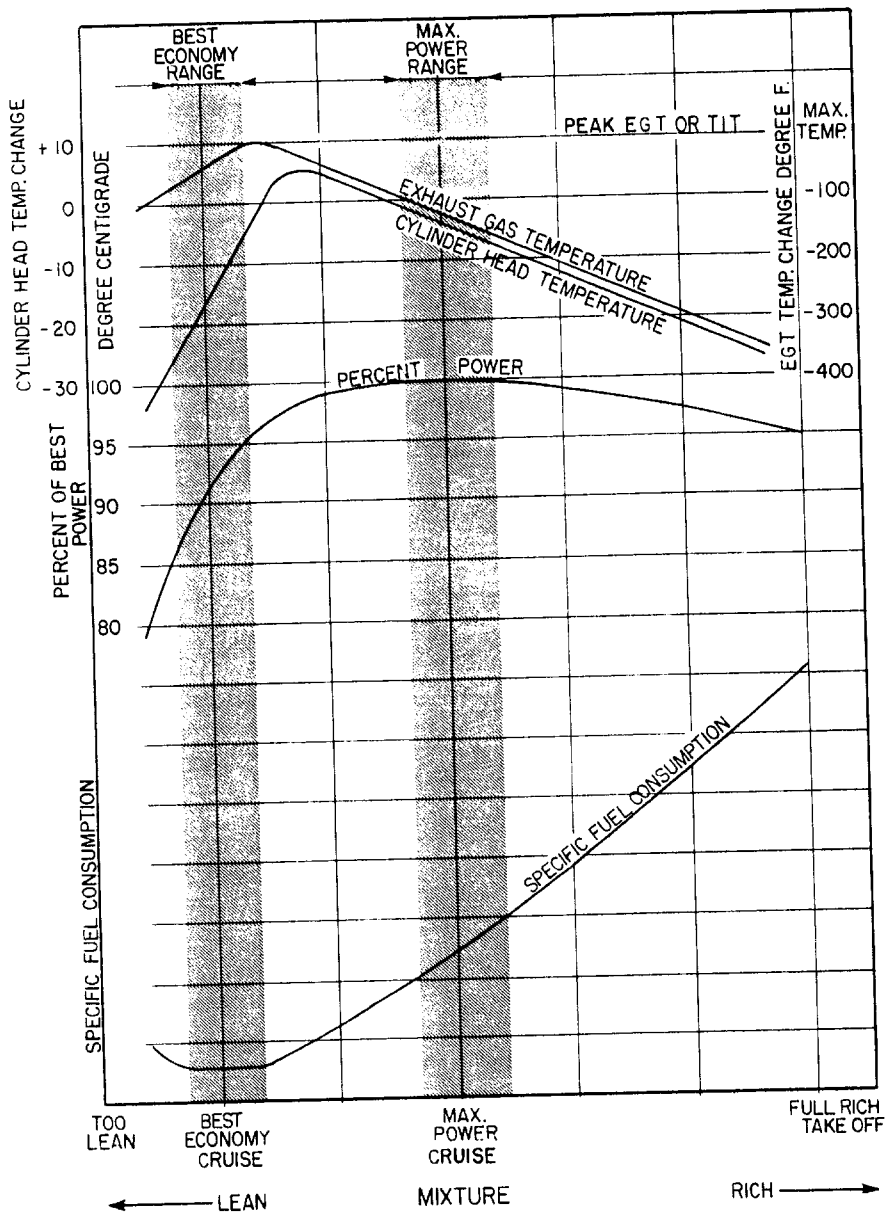

Figure 3-1. Representative Effect of Leaning on Cylinder Head Temperature, EGT (Exhaust Gas Temperature), Engine Power and Specific Fuel Consumption at Constant Engine RPM and Manifold Pressure



LYCOMING OPERATOR'S MANUAL

SECTION 3

O-320 & IO-320 SERIES

CURVE NO. 9540-B

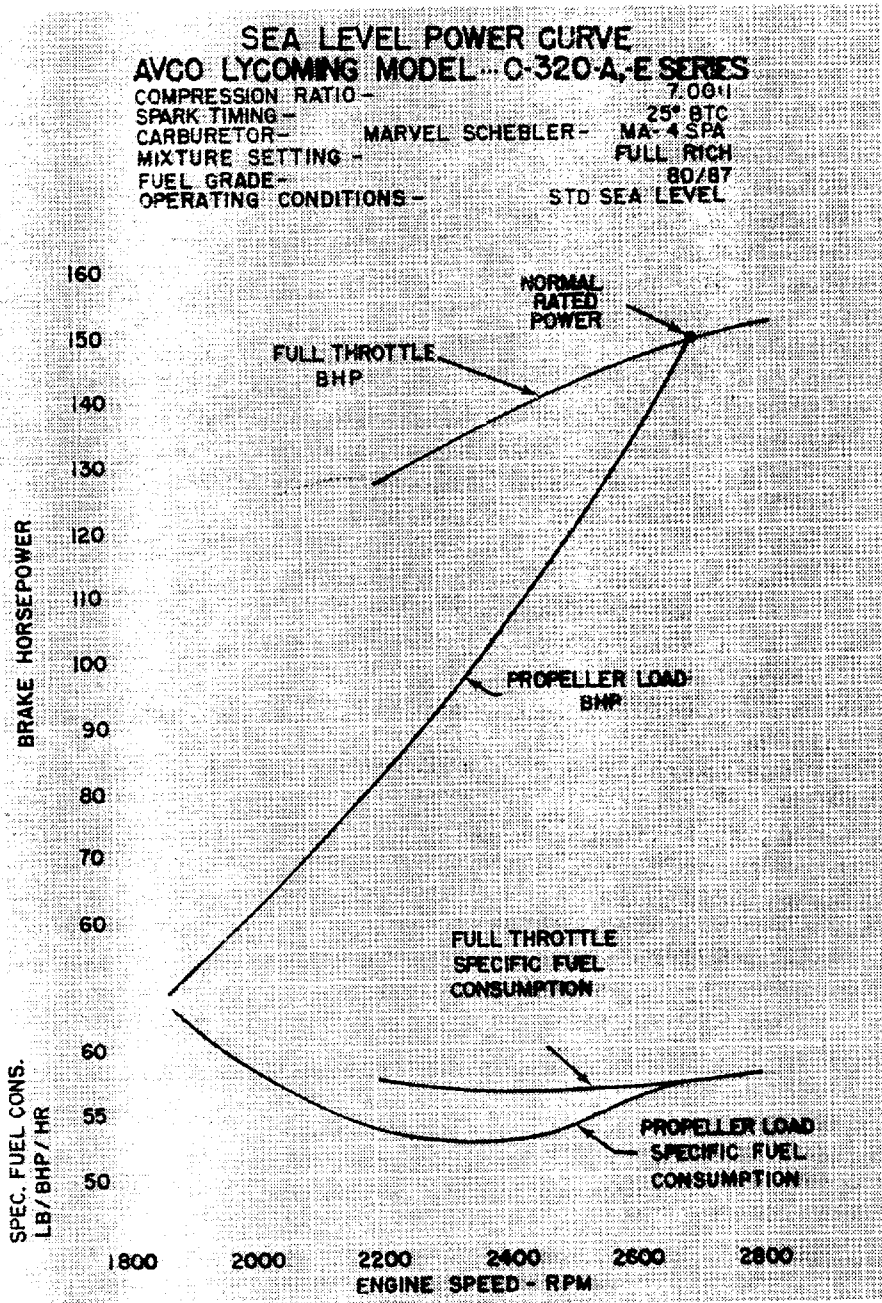

Figure 3-2. Sea Level Power Curve -
O-320-A and -E Series

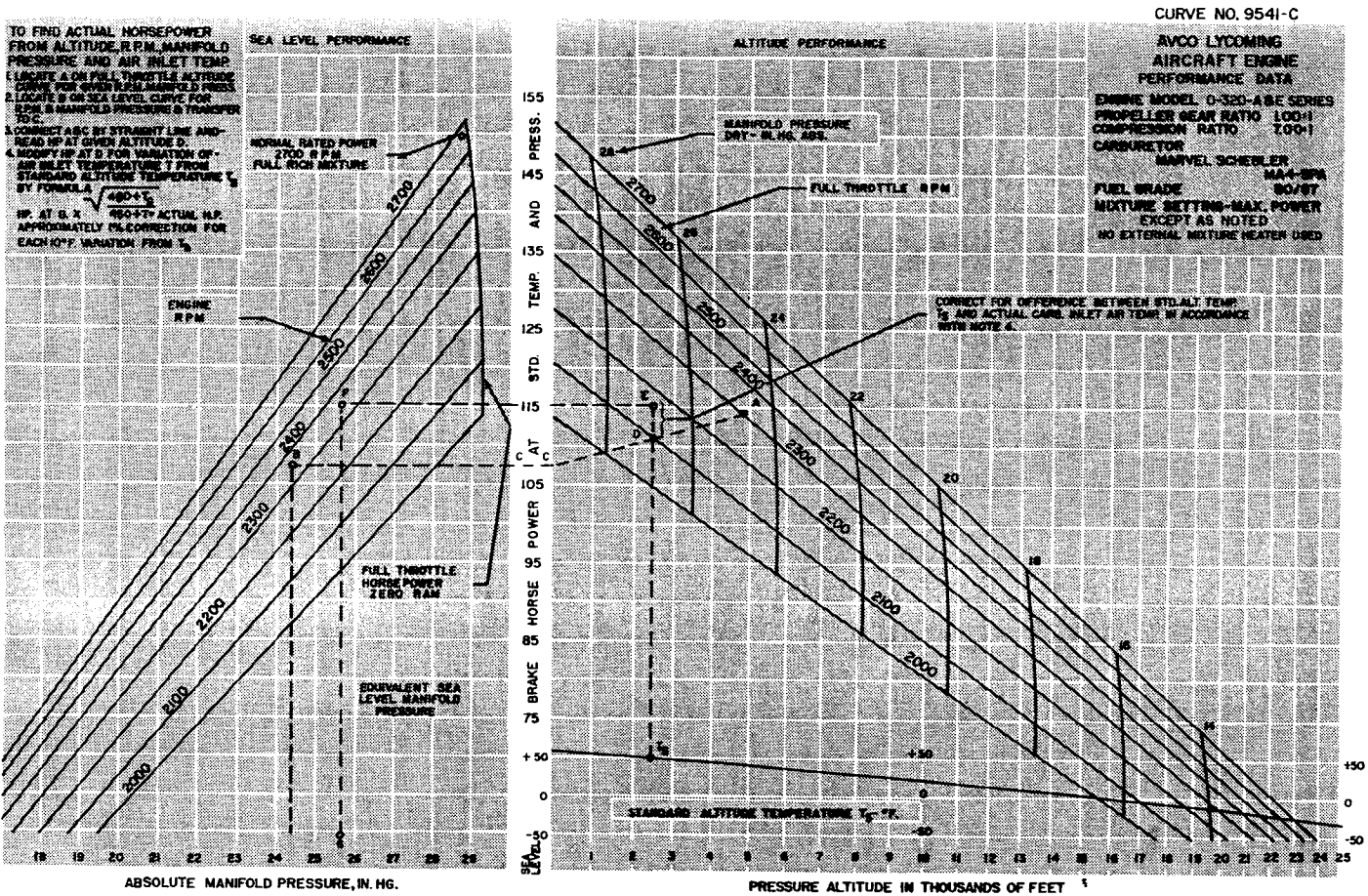

Figure 3-3. Sea Level and Altitude Performance - O-320-A and -E Series

AVCO LYCOMING OPERATOR'S MANUAL

SECTION 3

O-320 & IO-320 SERIES

CURVE NO. 10156

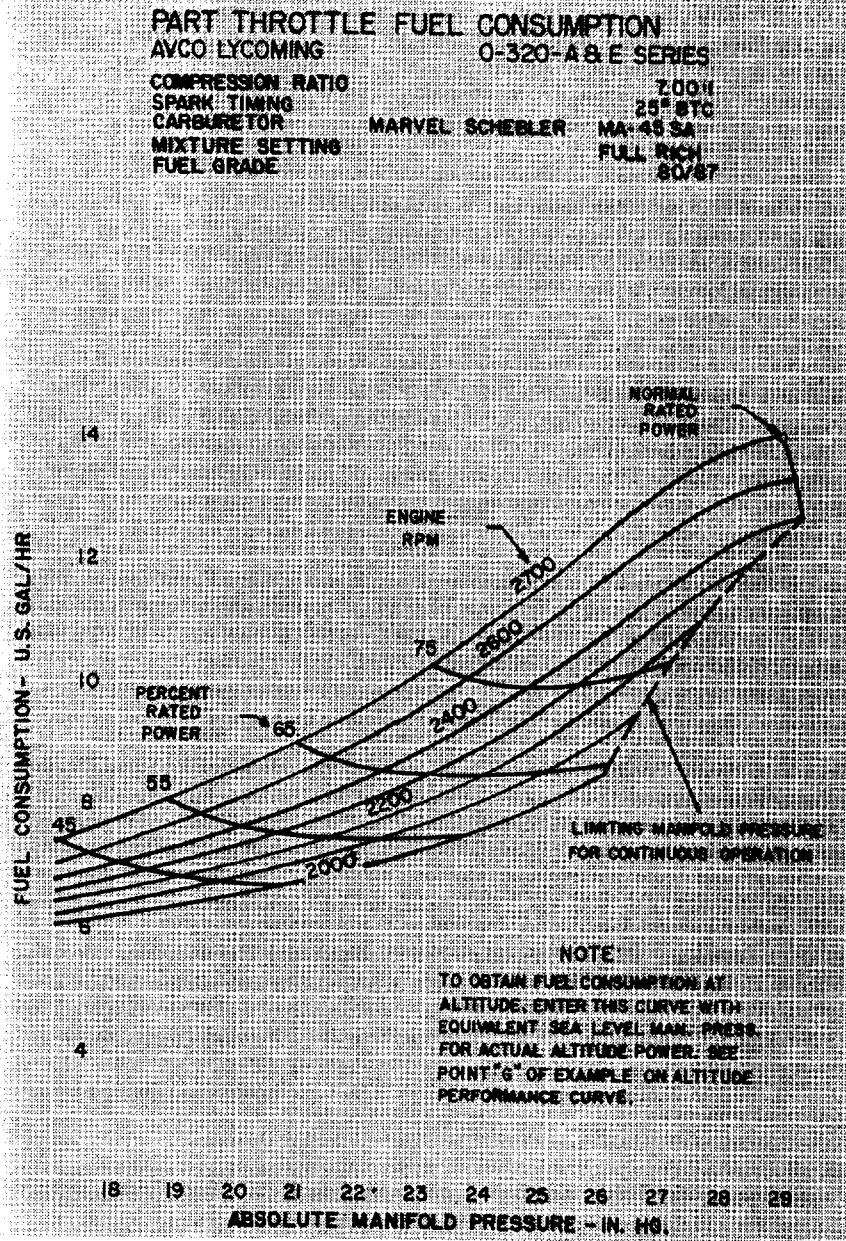

Figure 3-4. Part Throttle Fuel Consumption - O-320-A and -E Series

CURVE № 11259

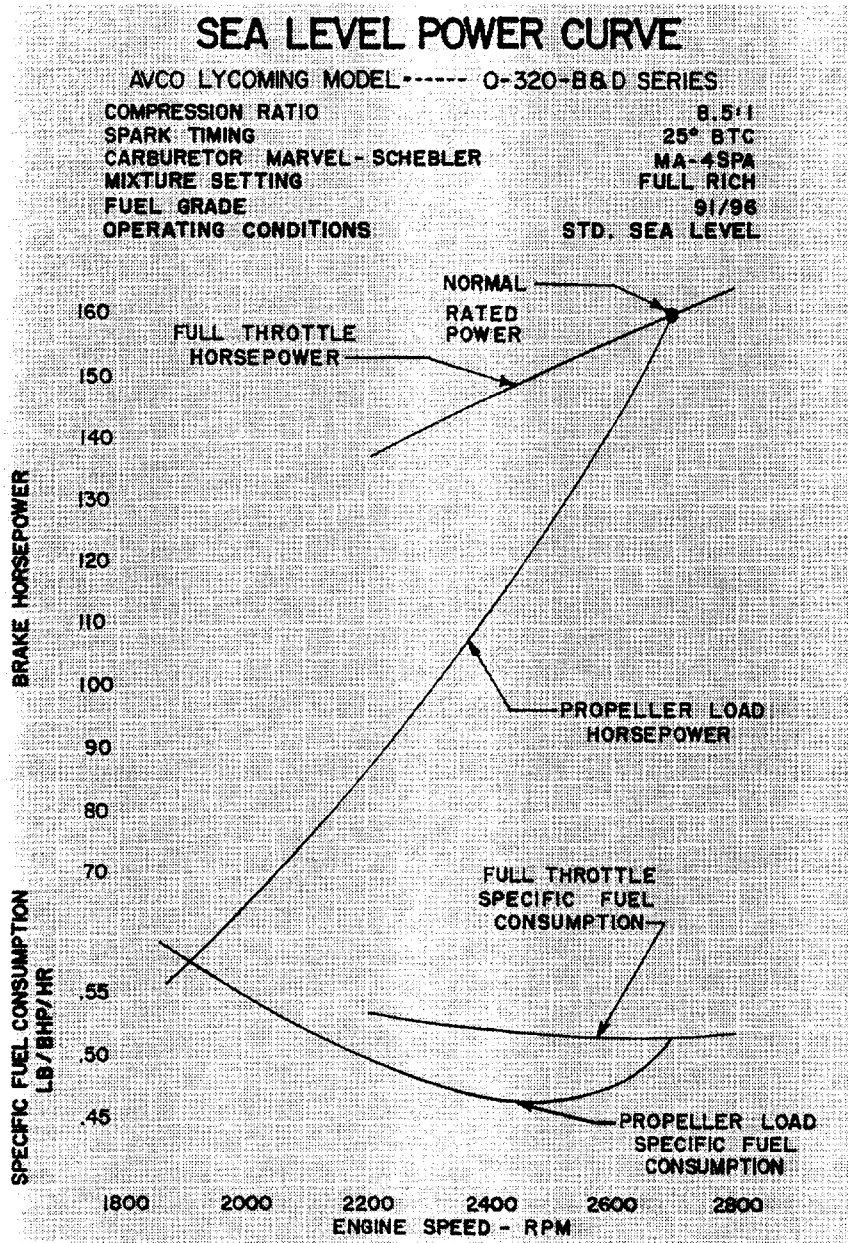

Figure 3-5. Sea Level Power Curve -
O-320-B and -D Series

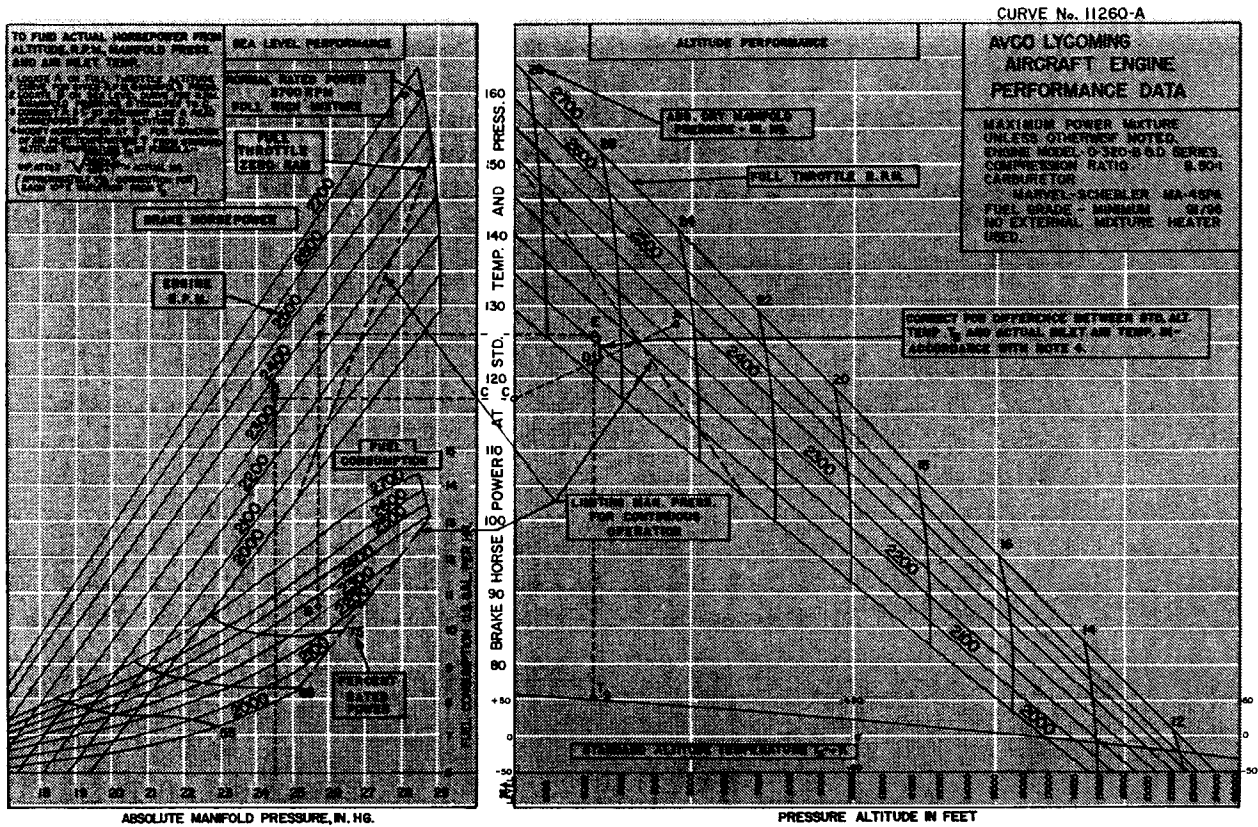

Figure 3-6. Sea Level and Altitude Performance - O-320-B and -D Series

AVCO LYCOMING OPERATOR'S MANUAL

O-320 & IO-320 SERIES

SECTION 3

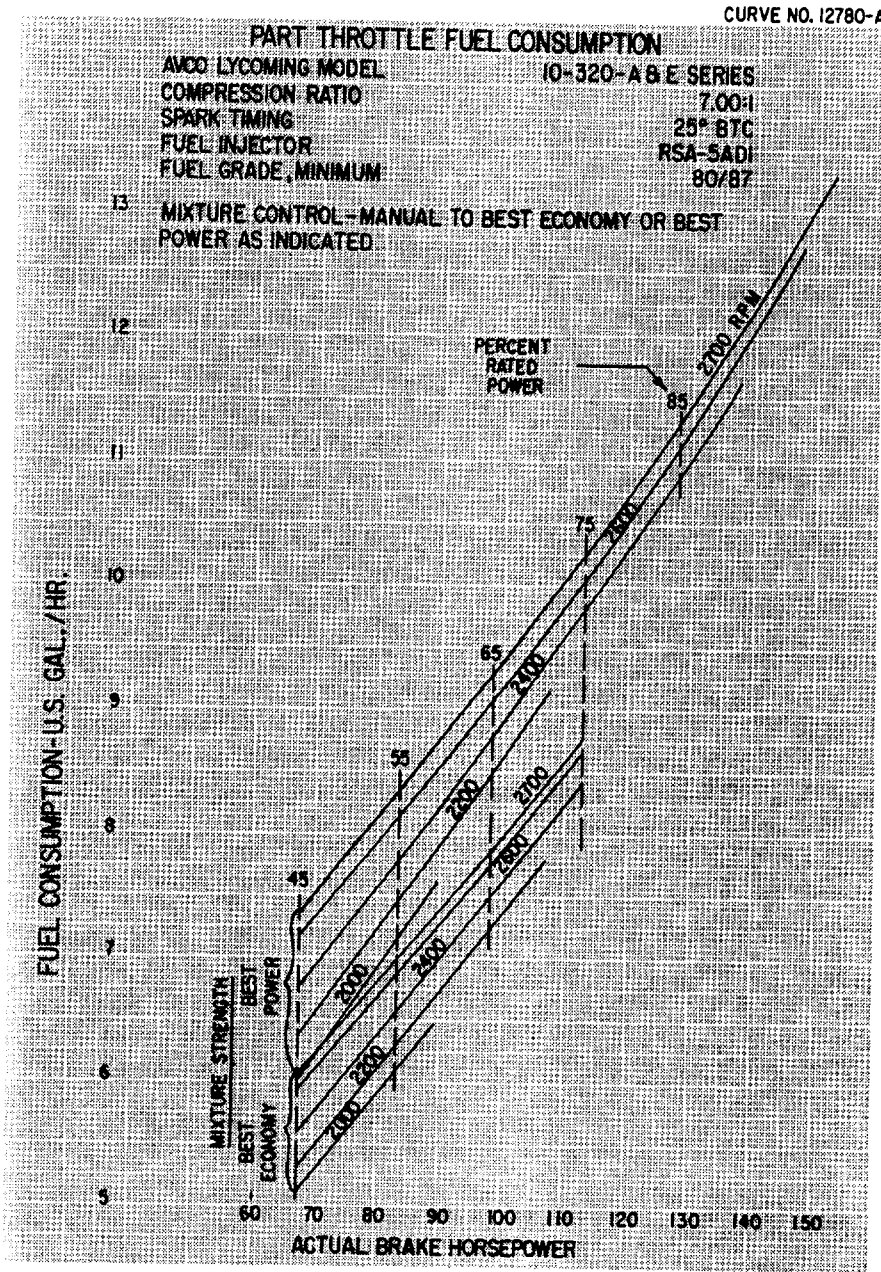

Figure 3-7. Part Throttle Fuel Consumption - IO-320-A and -E Series

Revised January, 1977

CURVE NOJ2781-A

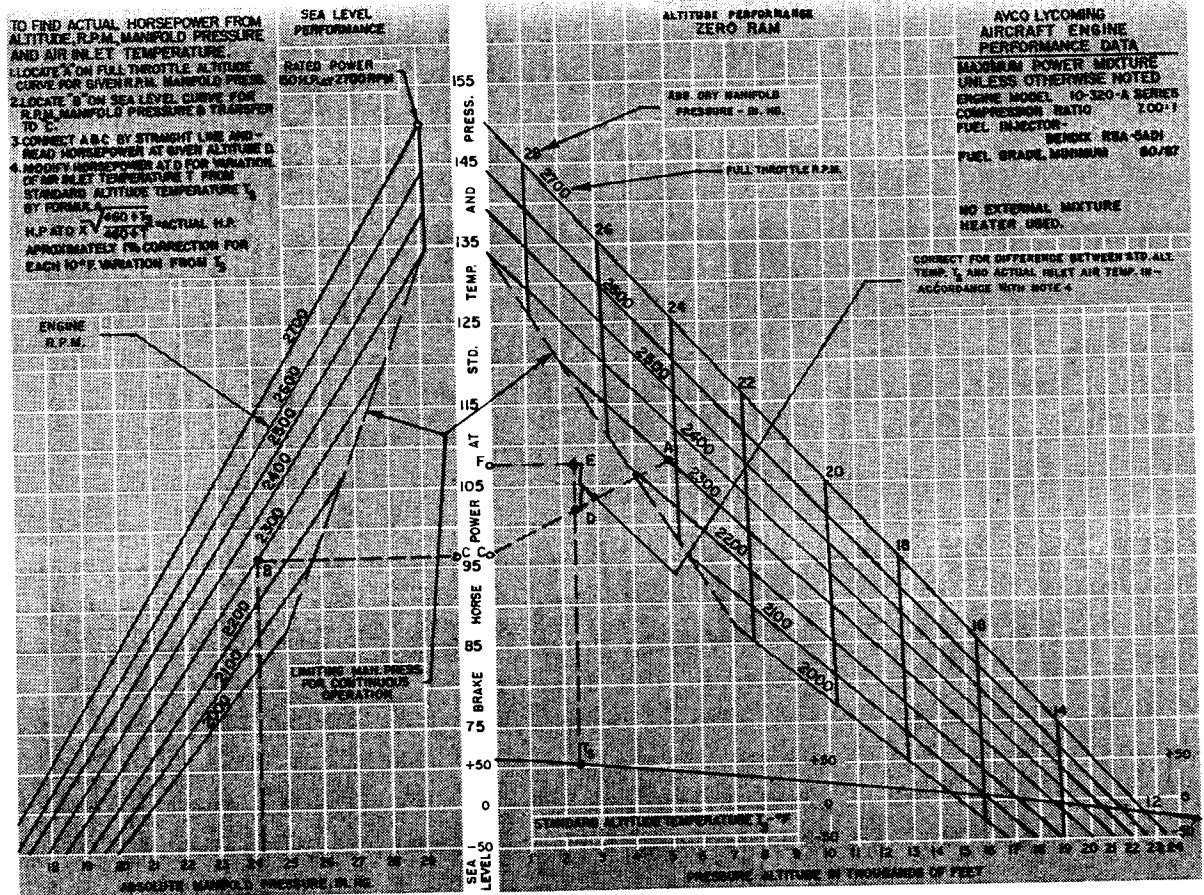

Figure 3-8. Sea Level and Altitude Performance - IO-320-A Series

CURVE NO. 13025-A

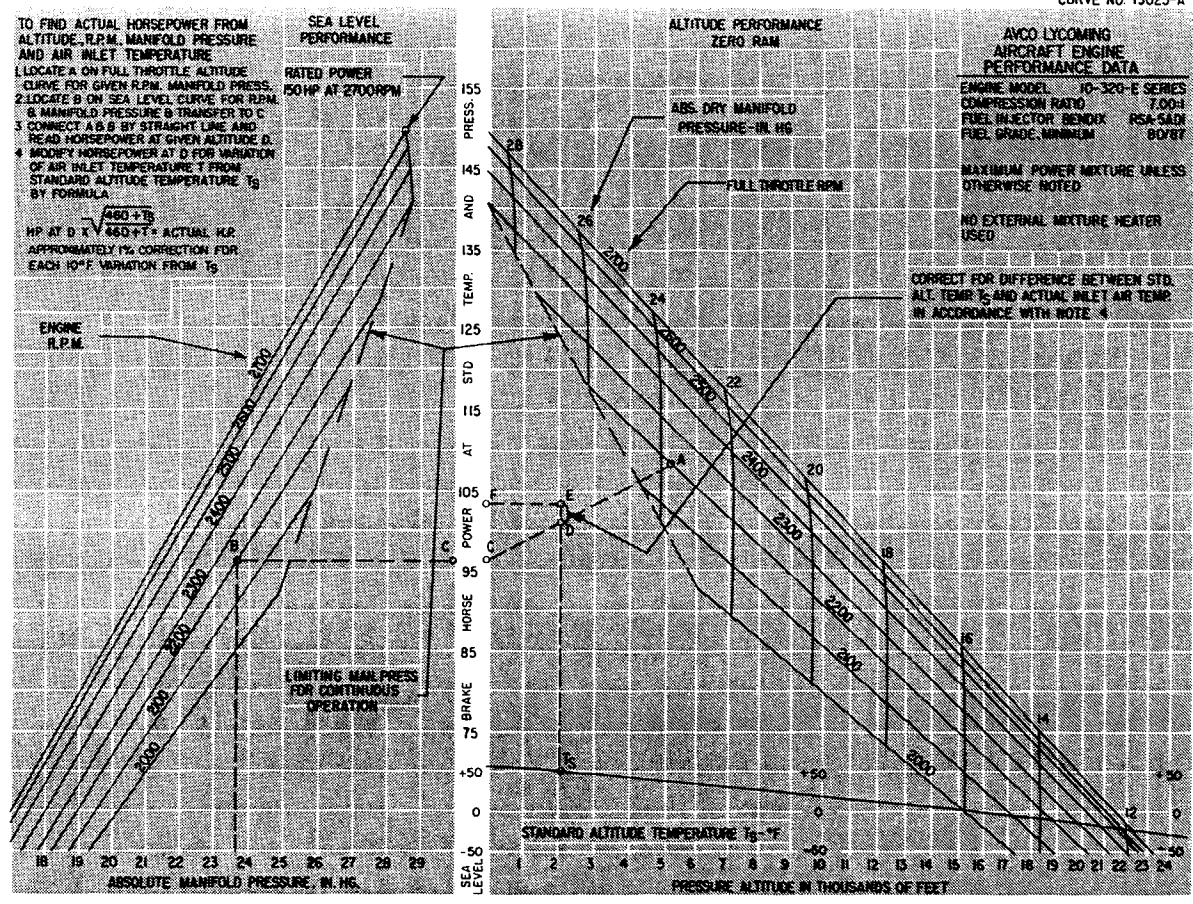

Figure 3-9. Sea Level and Altitude Performance - IO-320-E Series

Revised January, 1977

3-21

CURVE NO. 12883

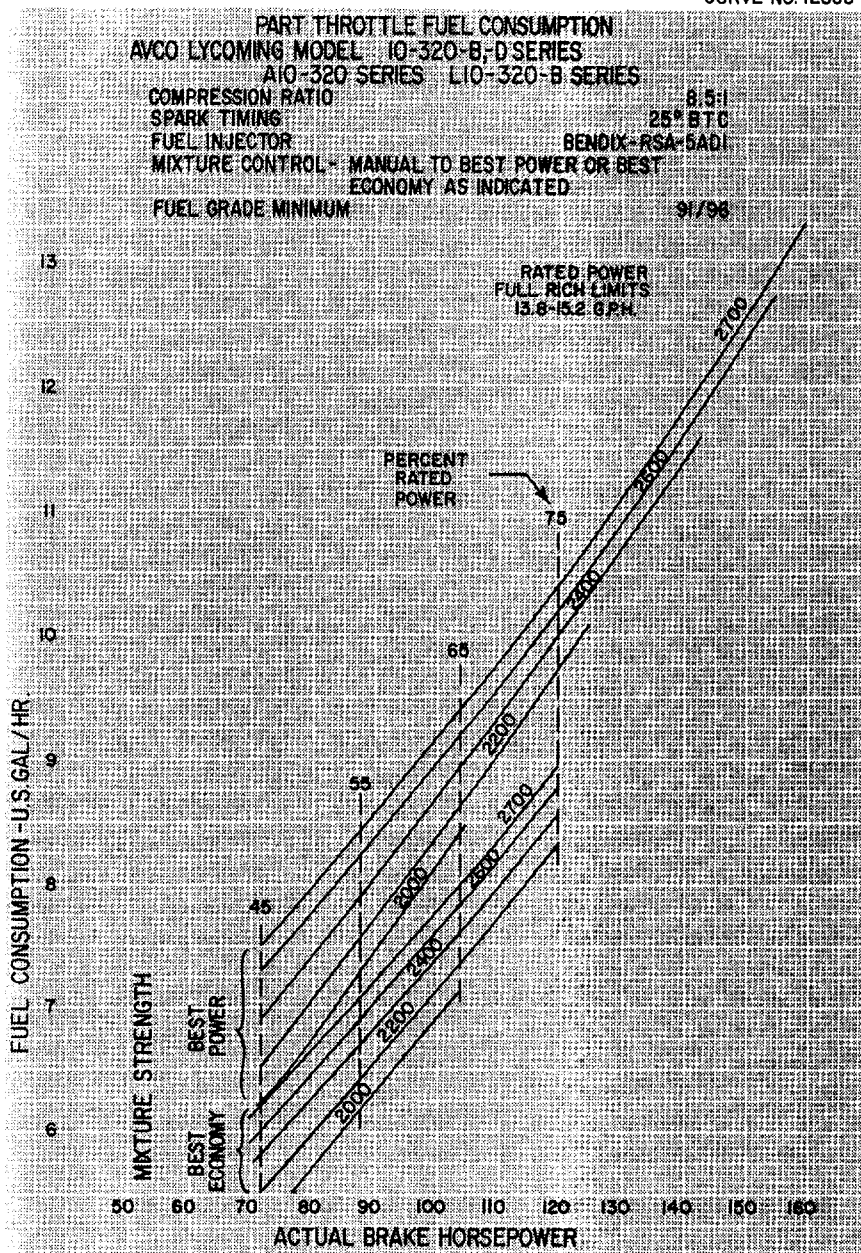
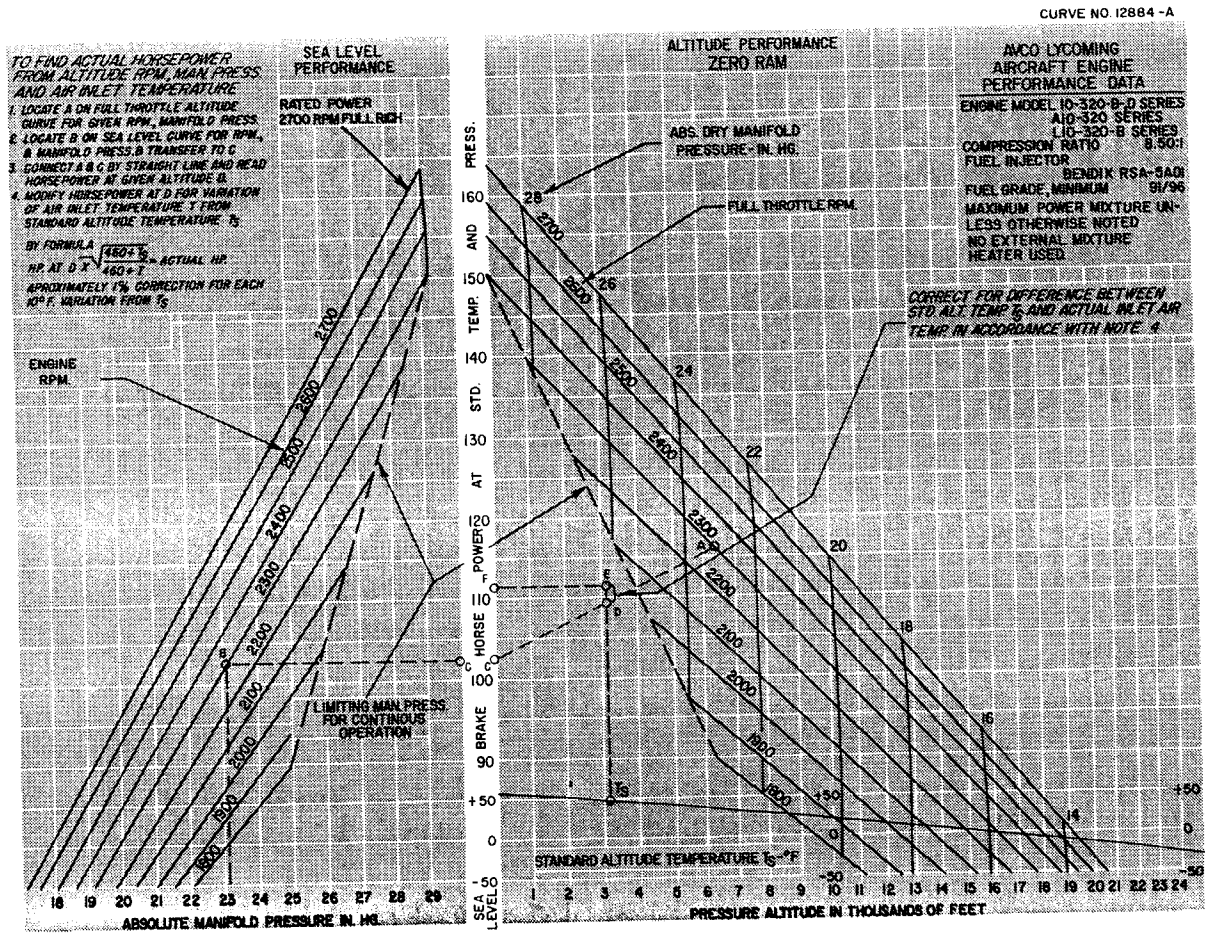

Figure 3-10. Part Throttle Fuel Consumption - IO-320-B, -D, AIO-320, LIO-320-B

Revised January, 1977



3-23

Figure 3-11. Sea Level and Altitude Performance - IO-320-B, -D, AIO-320, LIO-320-B



LYCOMING OPERATOR'S MANUAL

SECTION 3

O-320 & IO-320 SERIES

CURVE NO. 12999

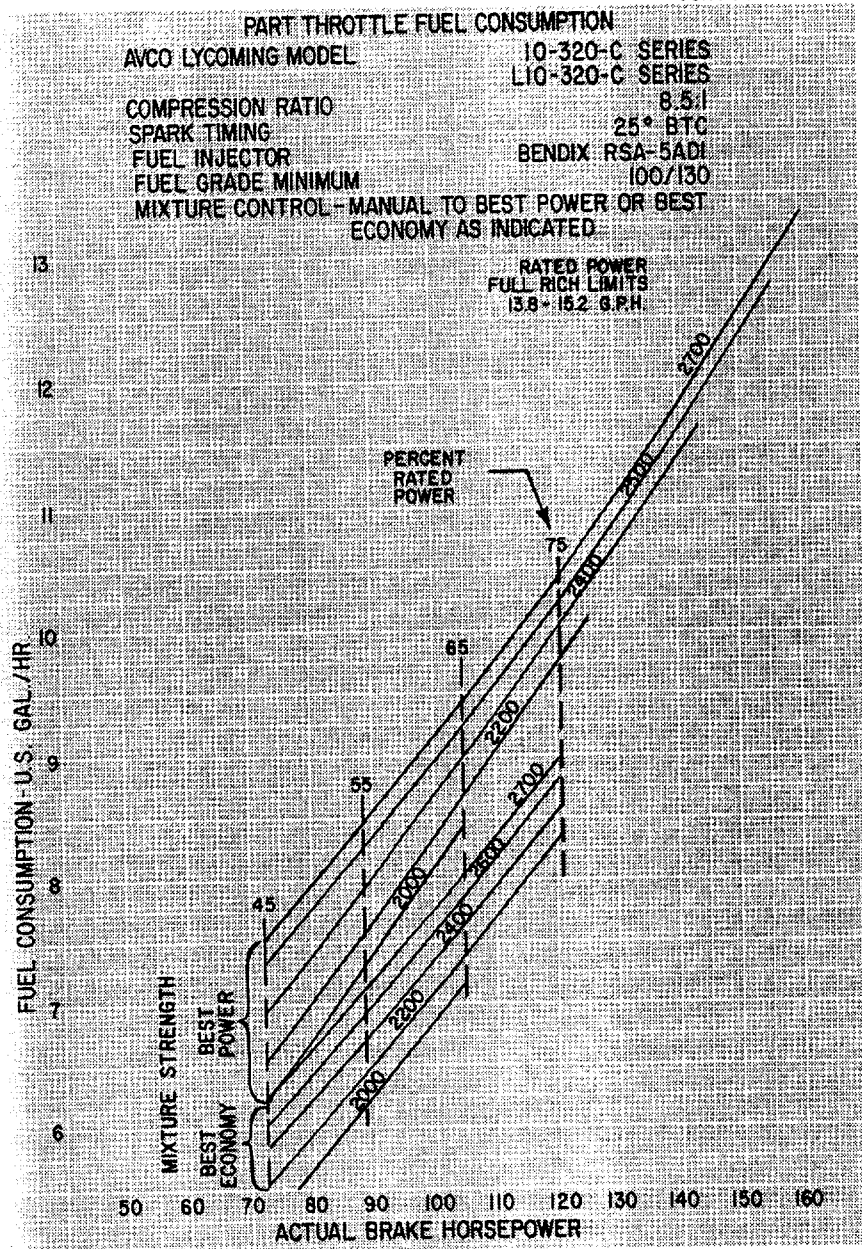

Figure 3-12. Part Throttle Fuel Consumption - IO-320-C, L10-320-C

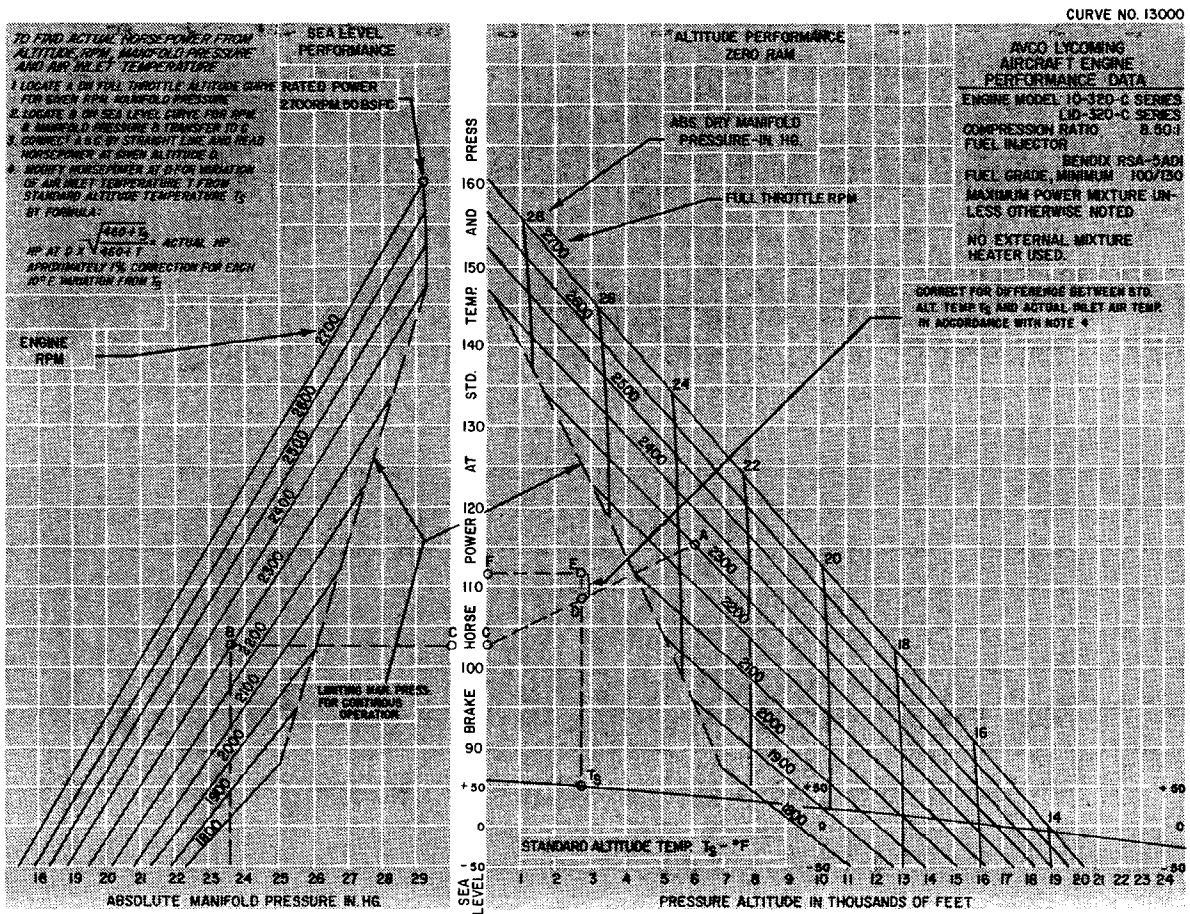

Figure 3-13. Sea Level and Altitude Performance - IO-320-C, LIO-320-C

AVCO LYCOMING OPERATOR'S MANUAL

SECTION 3

O-320 & IO-320 SERIES

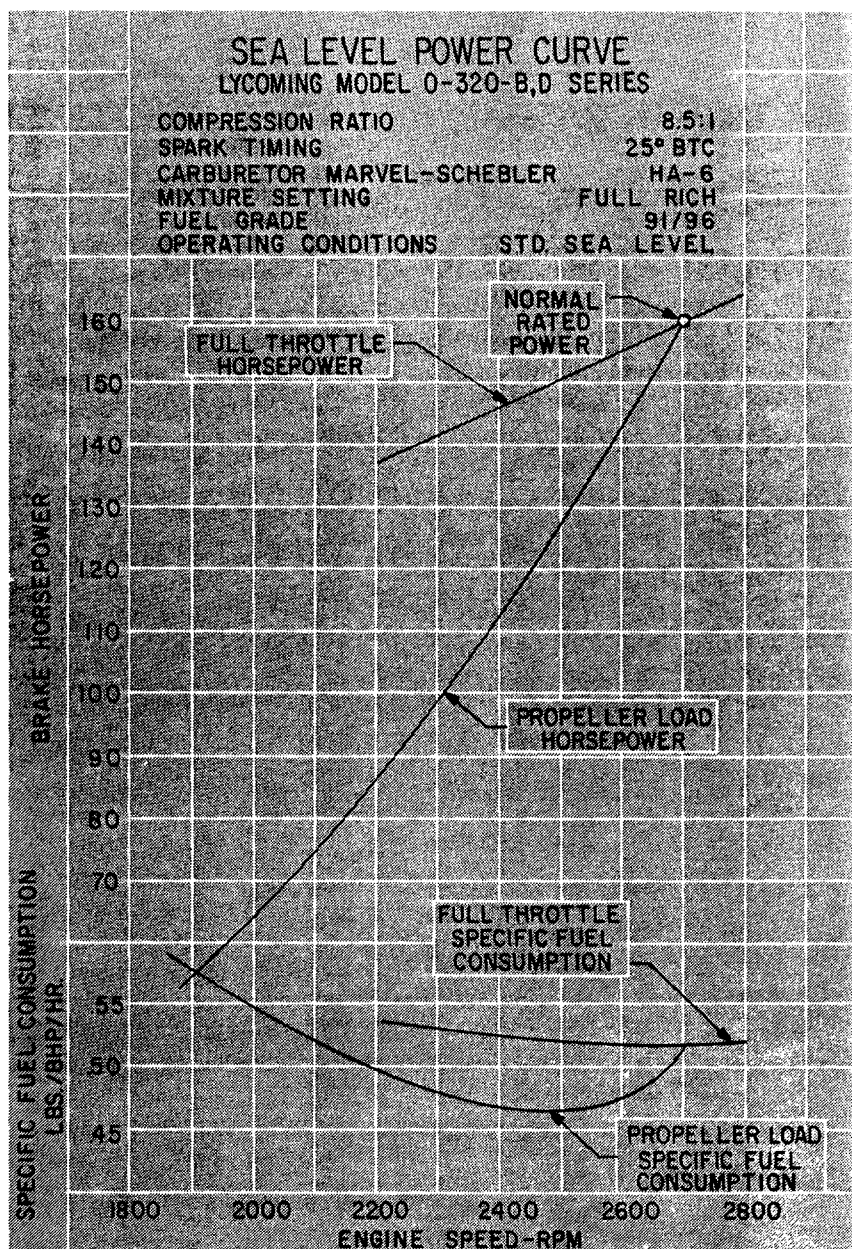

Figure 3-14. Sea Level Power - O-320-D1D

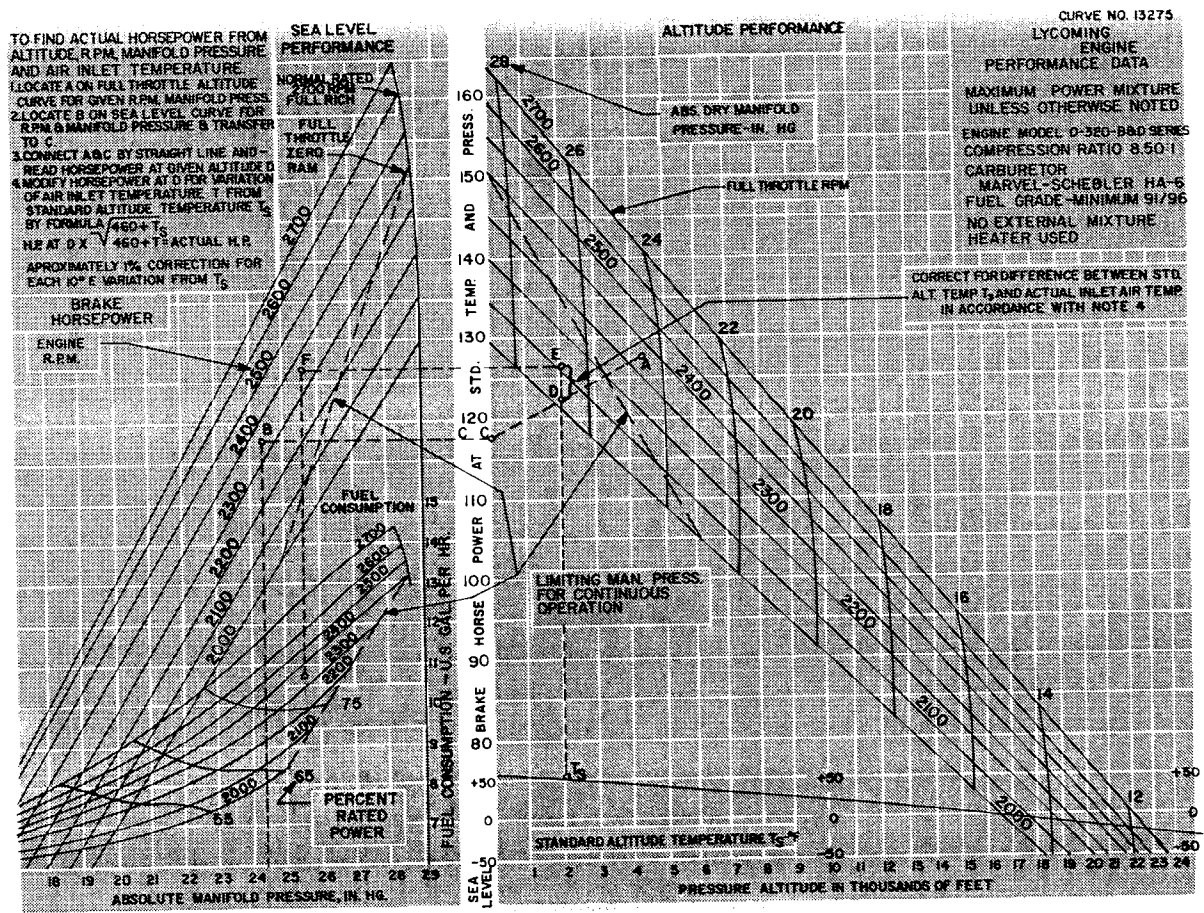

Figure 3-15. Sea Level and Altitude Performance - O-320-D1D

Added January, 1977

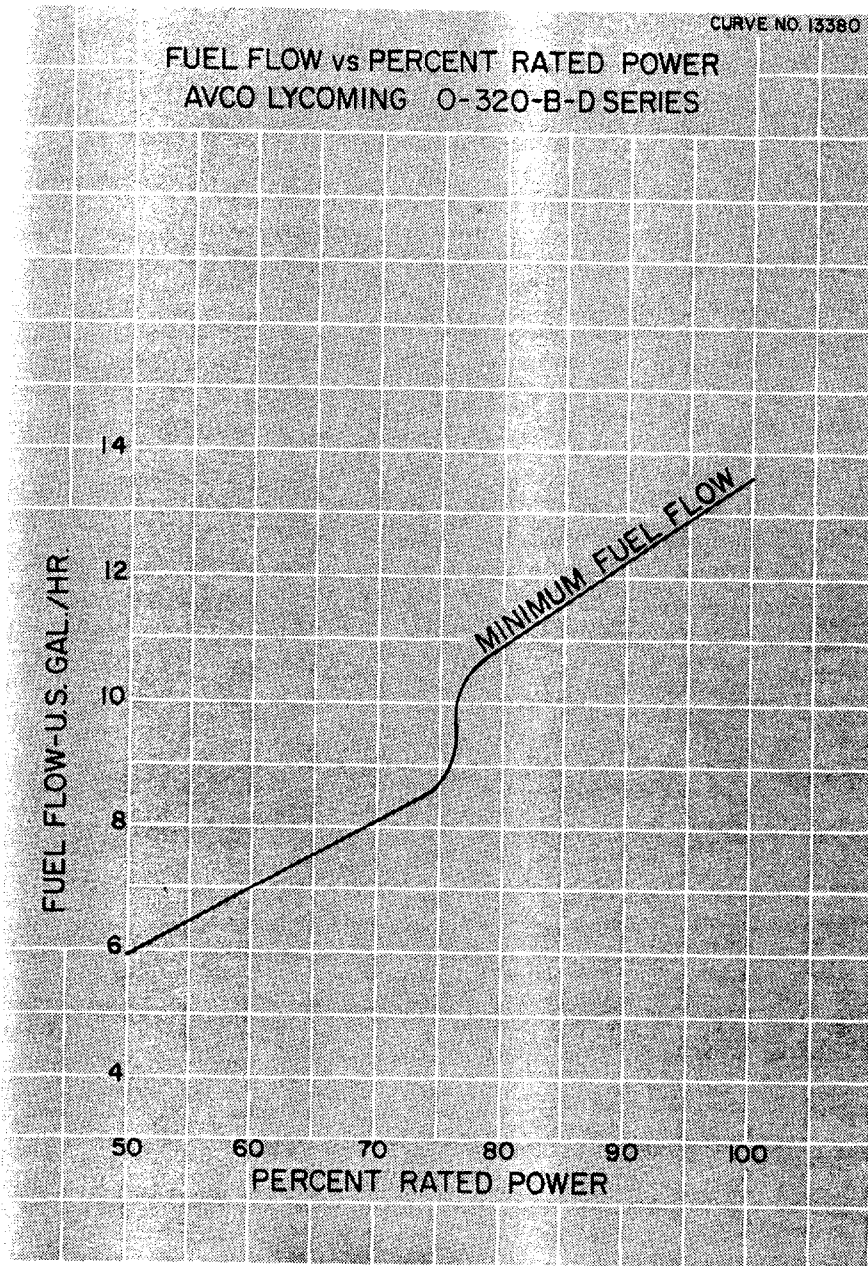

Figure 3-16. Fuel Flow vs Percent Rated Power

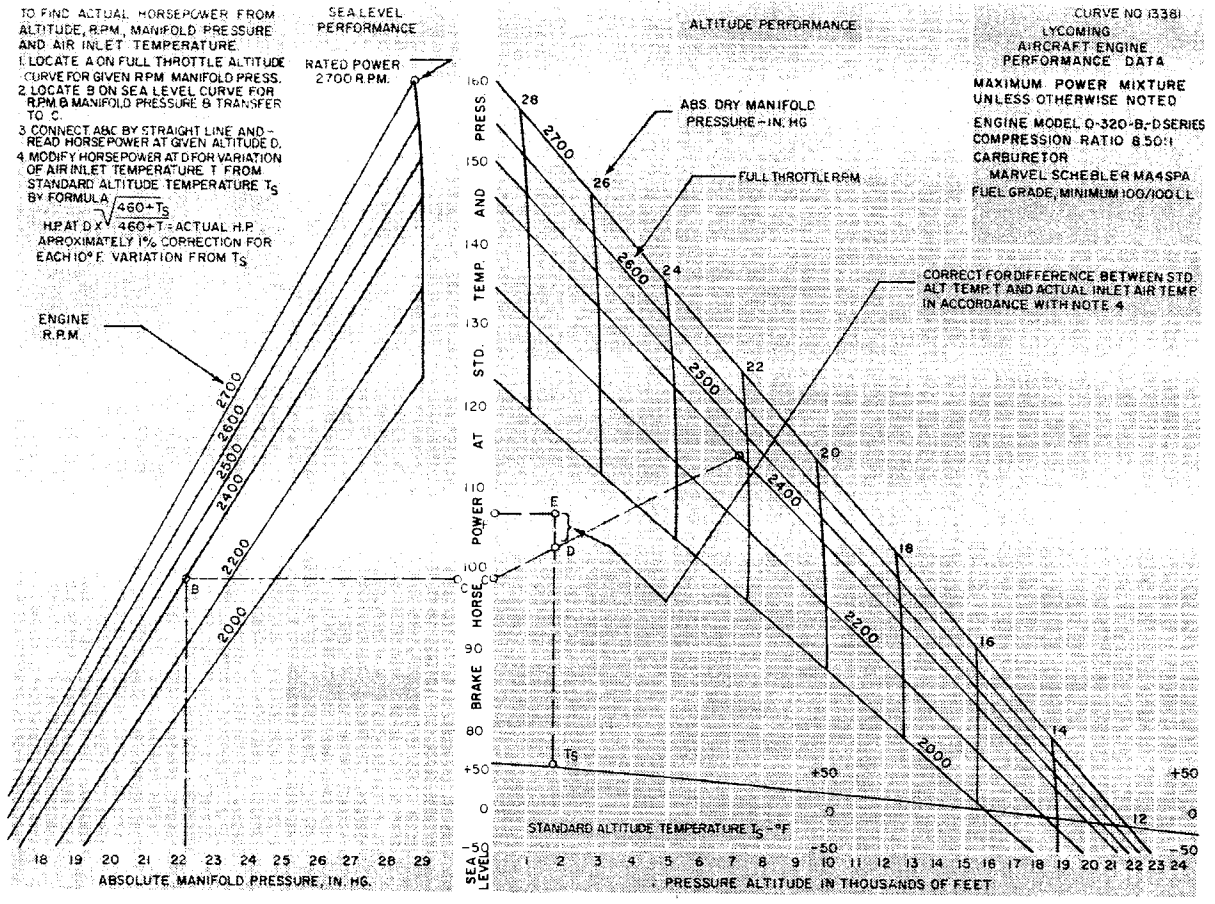

Figure 3-17. Sea Level and Altitude Performance Curve 0-320-D2J

Added May, 1980

SECTION

4

**PERIODIC
INSPECTION**

TEXTRON LYCOMING OPERATOR'S MANUAL

PERIODIC INSPECTION

	Page
General.....	4-1
Pre-Starting Inspection.....	4-1
Daily Pre-Flight.....	4-2
25 Hour Inspection.....	4-2
■ 50 Hour Inspection.....	4-3
100 Hour Inspection.....	4-4
400 Hour Inspection.....	4-5
Non-Scheduled Inspection.....	4-5

Revised January, 1993

TEXTRON LYCOMING OPERATOR'S MANUAL

O-320 & IO-320 SERIES

SECTION 4

SECTION 4

PERIODIC INSPECTION

NOTE

Perhaps no other factor is quite so important to safety and durability of the aircraft and its components as faithful and diligent attention to regular checks for minor troubles and prompt repair when they are found.

The operator should bear in mind that the items listed in the following pages do not constitute a complete aircraft inspection, but are meant for the engine only. Consult the airframe manufacturer's handbook for additional instructions.

Pre-Starting Inspection - The daily pre-flight inspection is a check of the aircraft prior to the first flight of the day. This inspection is to determine the general condition of the aircraft and engine.

The importance of proper pre-flight inspection cannot be over emphasized. Statistics prove several hundred accidents occur yearly directly responsible to poor pre-flight inspection.

Among the major causes of poor pre-flight inspection are lack of concentration, reluctance to acknowledge the need for a check list, carelessness bred by familiarity and haste.

TEXTRON LYCOMING OPERATOR'S MANUAL

SECTION 4

O-320 & IO-320 SERIES

1. DAILY PRE-FLIGHT.

- a. Be sure all switches are in the "Off" position.
- b. Be sure magneto ground wires are connected.
- c. Check oil level.
- d. See that fuel tanks are full.
- e. Check fuel and oil connections, note minor indications for repair at 50 hour inspection. Repair any major leaks before aircraft is flown.
- f. Open the fuel drain to remove any accumulation of water and sediment.
- g. Make sure all shields and cowling are in place and secure. If any are missing or damaged, repair or replacement should be made before the aircraft is flown.
- h. Check controls for general condition, travel and freedom of operation.
- i. Induction system air filter should be inspected and serviced in accordance with the airframe manufacturer's recommendations.

2. *25-HOUR INSPECTION.* After the first twenty-five hours operating time, new, remanufactured or newly overhauled engines should undergo a 50 hour inspection including draining and renewing lubricating oil. Engines equipped with oil pressure screen are required to comply with the following inspection after every 25 hours operating time.

a. *Lubrication System (Engines Equipped with Oil Pressure Screen) -*

- (1) Remove oil suction and oil pressure screens and check carefully for presence of metal particles that are indicative of internal engine damage. Clean and reinstall the oil suction and oil pressure screens. Drain and renew the lubricating oil.

NOTE

Change the oil at least every four (4) months even if the engine has not accumulated 25 hours since the last oil change.

TEXTRON LYCOMING OPERATOR'S MANUAL

O-320 & IO-320 SERIES

SECTION 4

3. 50—*HOUR INSPECTION*. In addition to the items listed for daily pre-flight inspection, the following maintenance checks should be made after every 50 hours of operation.

a. Ignition System -

(1) If fouling of spark plugs has been apparent, rotate bottom plugs to upper position.

(2) Examine spark plug leads of cable and ceramics for corrosion and deposits. This condition is evidence of either leaking spark plugs, improper cleaning of the spark plug walls or connector ends. Where this condition is found, clean the cable ends, spark plug walls and ceramics with a dry, clean cloth or a clean cloth moistened with methyl-ethyl ketone. All parts should be clean and dry before reassembly.

(3) Check ignition harness for security of mounting clamps and be sure connections are tight at spark plug and magneto terminals.

b. Fuel and Induction System - Check the primer lines (where applicable) for leaks and security of the clamps. Remove and clean the fuel inlet strainers. Check the mixture control and throttle linkage for travel, freedom of movement, security of the clamps and lubricate if necessary. Check the air intake ducts for leaks, security, filter damage; evidence of dust or other solid material in the ducts is indicative of inadequate filter care or damaged filter. Check vent lines for evidence of fuel or oil seepage; if present, fuel pump may require replacement.

c. Lubrication System (Engines Equipped with an External Full Flow Oil Filter) -

(1) Remove oil suction and oil pressure screens and check carefully for presence of metal particles that are indicative of internal engine damage.

(2) Replace external full flow oil filter element. Drain and renew lubricating oil.

TEXTRON LYCOMING OPERATOR'S MANUAL

SECTION 4

O-320 & IO-320 SERIES

NOTE

Change the oil at least every four (4) months even if the engine has not accumulated 50 hours since the last oil change.

(3) Check oil lines for leaks, particularly at connections for security of anchorage and for wear due to rubbing or vibration, for dents and cracks.

d. Exhaust System - Check attaching flanges at exhaust ports on cylinder for evidence of leakage. If they are loose, they must be removed and machined flat before they are reassembled and tightened. Examine exhaust manifolds for general condition.

e. Cooling System - Check cowling and baffles for damage and secure anchorage. Any damaged or missing part of the cooling system must be repaired or replaced before the aircraft resumes operation.

f. Cylinders - Check rocker box covers for evidence of oil leaks. If found, replace gasket and tighten screws to specified torque (50 inch lbs.).

Check cylinders for evidence of excessive heat which is indicated by burned paint on the cylinder. This condition is indicative of internal damage to the cylinder and, if found, its cause must be determined and corrected before the aircraft resumes operation.

4. 100—HOUR INSPECTION. In addition to the items listed for daily pre-flight and 50 hour inspection, the following maintenance checks should be made after every one hundred hours of operation.

a. Electrical System -

(1) Check all wiring connected to the engine or accessories. Any shielded cables that are damaged should be replaced. Replace clamps or loose wires and check terminals for security and cleanliness.

(2) Remove spark plugs; test, clean and regap. Replace if necessary.

TEXTRON LYCOMING OPERATOR'S MANUAL

O-320 & IO-320 SERIES

SECTION 4

b. *Magnetos* - Check breaker points for pitting and minimum gap. Check for excessive oil in the breaker compartment, if found, wipe dry with a clean lint free cloth. The felt located at the breaker points should be lubricated in accordance with the magneto manufacturer's instructions. Check magneto to engine timing. Timing procedure is described in Section 5, 1, b of this manual.

c. *Engine Accessories* - Engine mounted accessories such as pumps, temperature and pressure sensing units should be checked for secure mounting, tight connections.

d. *Cylinders* - Check cylinders visually for cracked or broken fins.

e. *Engine Mounts* - Check engine mounting bolts and bushings for security and excessive wear. Replace any bushings that are excessively worn.

f. *Fuel Injector Nozzles and Fuel Lines* - Check fuel injector nozzles for looseness. Tighten to 60 inch pounds torque. Check fuel lines for fuel stains which are indicative of fuel leaks. Repair or replacement must be accomplished before the aircraft resumes operation.

5. *400—HOUR INSPECTION*. In addition to the items listed for daily pre-flight, 50 hour and 100 hour inspections, the following maintenance check should be made after every 400 hours of operation.

Valve Inspection - Remove rocker box covers and check for freedom of valve rockers when valves are closed. Look for evidence of abnormal wear or broken parts in the area of the valve tips, valve keeper, springs and spring seats. If any indications are found, the cylinder and all of its components should be removed (including the piston and connecting rod assembly) and inspected for further damage. Replace any parts that do not conform with limits shown in the latest edition of Special Service Publication No. SSP2070.

6. *NON—SCHEDULED INSPECTIONS*. Occasionally, service bulletins or service instructions are issued by Textron Lycoming Reciprocating Engine Division that require inspection procedures that are not listed in this manual. Such publications, usually are limited to specified engine models and become obsolete after corrective modification has been accomplished. All such publications are available from Textron Lycoming distributors, or from the factory by subscription. Consult the latest edition of Service Letter No. L114 for subscription information. Maintenance facilities should have an up-to-date file of these publications available at all times.

SECTION

5

**MAINTENANCE
PROCEDURES**

MAINTENANCE PROCEDURES

	Page
Ignition and Electrical System5-1
Ignition Harness and Wire Replacement5-1
Timing Magnetos to Engine5-1
Fuel System5-5
Repair of Fuel Leaks5-5
Carburetor or Fuel Injector Fuel Inlet Screen Assembly5-6
Fuel Grades and Limitations5-6
Air Intake Ducts and Filter5-6
Idle Speed and Mixture Adjustment5-6
Lubrication System5-7
Oil Grades and Limitations5-7
Oil Suction and Oil Press. Screens5-7
Oil Relief Valve, Non-Adjustable5-8
Oil Relief Valve, Adjustable5-8
Cylinders5-8
Removal of Cylinder Assembly5-8

MAINTENANCE PROCEDURES (CONT.)

	Page
Removal of Valves and Valve Springs	5-9
Removal of Pistons from Connecting Rods	5-9
Removal of Hydraulic Tappets and Plunger Assemblies	5-10
Assembly of Hydraulic Tappet Plunger Assemblies	5-10
Assembly of Valves in Cylinder	5-10
Assembly of Cylinder and Related Parts	5-11
Generator or Alternator Drive Belt Tension	5-14

SECTION 5**MAINTENANCE PROCEDURES**

The procedures described in this section are provided to guide and instruct personnel in performing such maintenance operations that may be required in conjunction with the periodic inspections listed in the preceding section. No attempt is made to include repair and replacement operations that will be found in the applicable Avco Lycoming Overhaul Manual.

1. IGNITION AND ELECTRICAL SYSTEM.

a. Ignition Harness and Wire Replacement - In the event that an ignition harness or an individual lead is to be replaced, consult the wiring diagram to be sure harness is correctly installed. Mark location of clamps and clips to be certain the replacement is clamped at correct locations.

b. Timing Magnetos to Engine - Although several combinations of magnetos are used on this series engines, (see Table of Models for model application) the timing procedures, with the exception of the method of turning the magnetos to the correct breaker position, are the same for all magnetos.

NOTE

Either the impulse coupling or retard breaker magneto (whichever is applicable) is installed on the left side of the engine.

(1) Remove a spark plug from No. 1 cylinder and place a thumb over the spark plug hole. Rotate the crankshaft in direction of normal rotation until the compression stroke is reached, this is indicated by a positive pressure inside the cylinder tending to push the thumb off the spark plug hole. Continue rotating the crankshaft in direction of normal rotation until the advance timing mark on the front face of the starter ring gear is in exact alignment with the small hole located at the two o'clock position on the front face of the starter housing. (Starter ring gear may be marked at 20° and 25°. Consult engine specifications, or nameplate, for correct timing mark for your installation.)

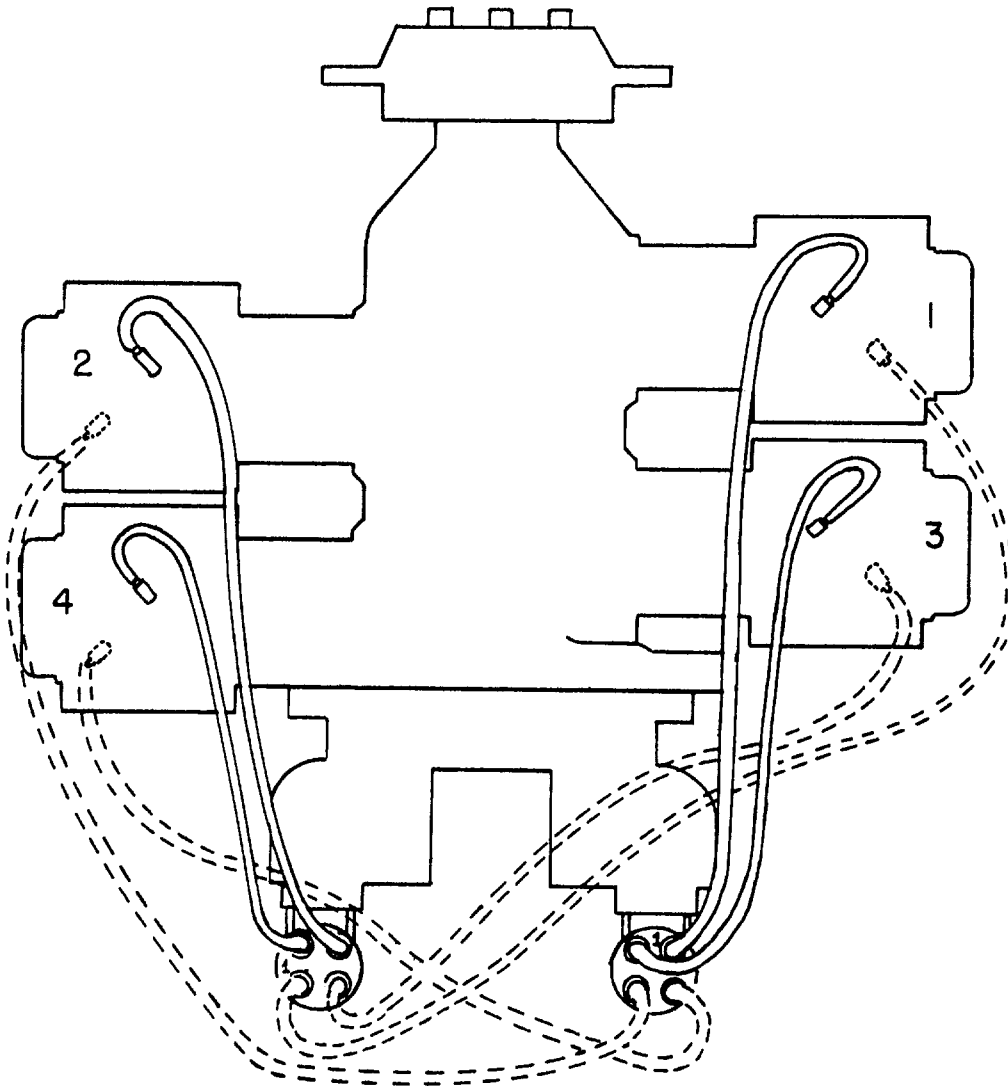

FIRING ORDER
MAGNETO-Left Hand Rotation 1-3-2-4
MAGNETO-Right Hand Rotation 1-4-2-3

Figure 5-1. Ignition Wiring Diagram

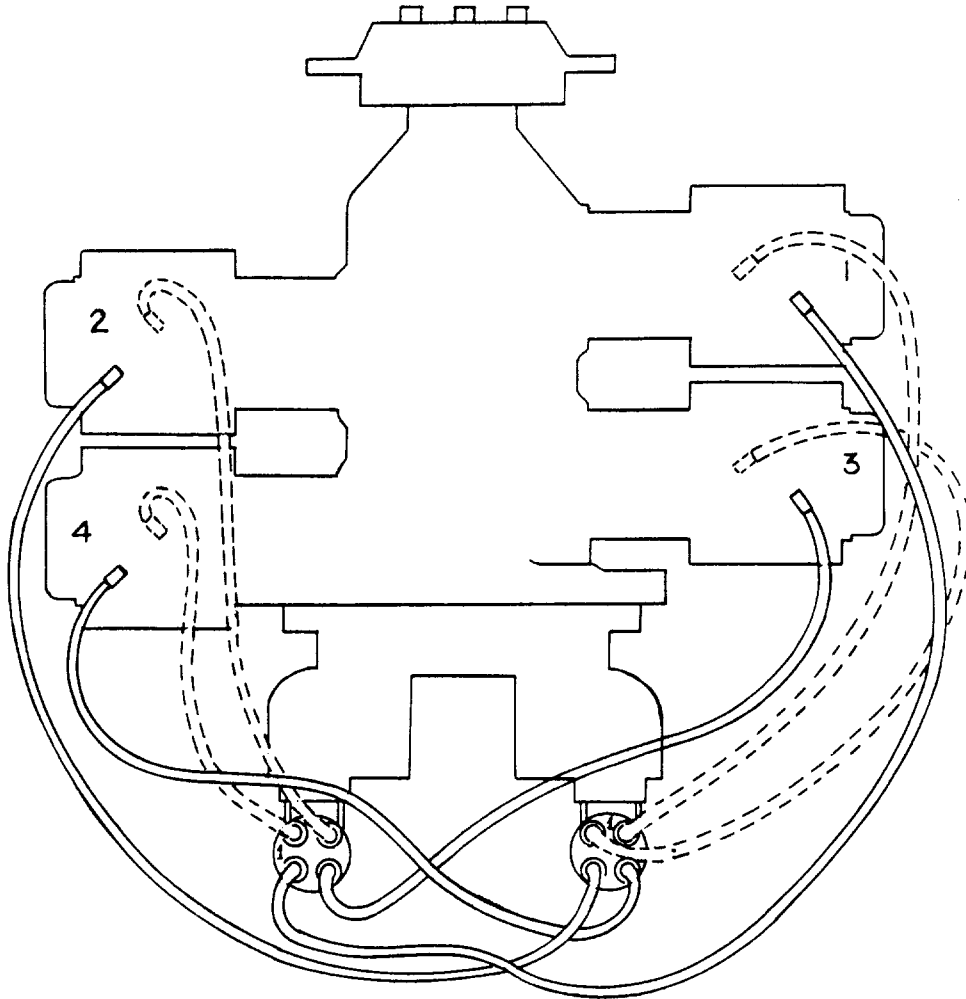

FIRING ORDER
MAGNETO-Left Hand Rotation 1-3-2-4
MAGNETO-Right Hand Rotation 1-4-2-3

Figure 5-2. Ignition Wiring Diagram (Optional)

NOTE

If the crankshaft is accidentally turned in the direction opposite normal rotation, repeat the above procedure as accumulated backlash will make the final timing incorrect.

(2) At this point, the engine is ready for assembly of the magnetos.

(a) *Bendix Magnetos* - Remove the inspection plugs from both magnetos and turn the driveshafts in direction of normal rotation until the first painted chamfered tooth on the distributor gear is aligned in the center of the inspection window.

(b) *Slick Magnetos* - Remove the bottom vent plugs and "spark out" the magnetos. This is accomplished in the following manner.

(*Impulse Coupling Magneto*) Hold the T1 or B1 lead wire spring 1/16 in. to 1/8 in. away from the magneto frame and turn the impulse coupling one click at a time until a strong spark jumps between the spring and the frame. Hold the magneto firmly so the coupling will not move beyond the point where it trips and the spark occurs. Reverse the rotation approximately 25° until the timing pin hole appears in the center of the vent plug hole. Hold the rotor by inserting the timing pin and line the timing pin with the center of the vent plug hole.

(*Conventional Magneto*) Hold the B1 lead wire spring 1/8 in. away from the frame. Turn the gear counter-clockwise vigorously through the flux lines until a strong spark occurs at the lead. Reverse the rotation into the flux until the timing pin hole appears in the center of the vent plug hole and insert the timing pin into the hole.

(3) Being sure that the gear does not move from this position, install gaskets and magnetos on the engine. Secure with washers and nuts; tighten only finger tight.

NOTE

In order to turn the shaft on an impulse coupling magneto, depress the pawl on the impulse coupling with the finger.

(4) Using a battery powered timing light, attach the positive lead to a suitable terminal connected to the ground terminal of the magneto and the negative lead to any unpainted portion of the engine. Rotate the magneto in its mounting flange to a point where the light comes on, then slowly turn it in the opposite direction until the light goes out. Bring the magneto back slowly until the light just comes on. Repeat this with the second magneto.

NOTE

Some timing lights operate in the reverse manner as described above, the light comes on when the breaker points open. Check your timing light instructions.

(5) After both magnetos have been timed to the engine, check, as described below, to ascertain that both magnetos are set to fire together.

(6) Back off the crankshaft a few degrees, the timing lights should go out. Bring the crankshaft slowly back in direction of normal rotation until the timing mark and the hole in the starter housing are in alignment. At this point, both lights should go on simultaneously. Tighten nuts to specified torque.

c. Generator or Alternator Output - The generator or alternator (whichever is applicable) should be checked to determine that the specified voltage and current are being obtained.

2. FUEL SYSTEM.

a. Repair of Fuel Leaks - In the event a line or fitting in the fuel system is replaced, only a fuel soluble lubricant, such as clean engine oil or Loctite Hydraulic Sealant, may be used on the threads. Any other thread lubricant or compound must not be used.

b. Carburetor or Fuel Injector Fuel Inlet Screen Assembly - Remove the assembly and check the screen for distortion or openings in the strainer. Replace for either of these conditions. Clean screen assembly in solvent and dry with compressed air and reinstall. The fuel inlet screen assembly is tightened to 35-40 inch pounds on carburetors and 65-70 inch pounds on fuel injectors.

c. Fuel Grades and Limitations - The recommended aviation grade fuel for the subject engines is listed in Section 3, item 10.

In the event that the specified fuel is not available at some locations, it is permissible to use higher octane fuel. Fuel of a lower octane than specified is not to be used. Under no circumstances should automotive fuel be used (regardless of octane rating).

NOTE

It is recommended that personnel be familiar with Service Instruction No. 1070 regarding specified fuel for Avco Lycoming engines.

d. Air Intake Ducts and Filter - Check all air intake ducts for dirt or restrictions. Inspect and service air filters as instructed in the airframe manufacturer's handbook.

e. Idle Speed and Mixture Adjustment -

(1) Start the engine and warm up in the usual manner until oil and cylinder head temperatures are normal.

(2) Check magnetos. If the "mag-drop" is normal, proceed with idle adjustment.

(3) Set throttle stop screw so that the engine idles at the airframe manufacturer's recommended idling RPM. If the RPM changes appreciably after making idle adjustment during the succeeding steps, readjust the idle speed to the desired RPM.

TEXTRON LYCOMING OPERATOR'S MANUAL

O-320 & IO-320 SERIES

SECTION 5

(4) When the idling speed has been stabilized, move the cockpit mixture control lever with a smooth, steady pull toward the "Idle Cut-Off" position and observe the tachometer for any change during the leaning process. Caution must be exercised to return the mixture control to the "Full Rich" position before the RPM can drop to a point where the engine cuts out. An increase of more than 50 RPM while "leaning out" indicates an excessively rich idle mixture. An immediate decrease in RPM (if not preceded by a momentary increase) indicates the idle mixture is too lean.

If the above indicates that the idle adjustment is too rich or too lean, turn the idle mixture adjustment in the direction required for correction, and check this new position by repeating the above procedure. Make additional adjustments as necessary until a check results in a momentary pick-up of approximately 50 RPM. Each time the adjustment is changed, the engine should be run up to 2000 RPM to clear the engine before proceeding with the RPM check. Make final adjustment of the idle speed adjustment to obtain the desired idling RPM with closed throttle. The above method aims at a setting that will obtain maximum RPM with minimum manifold pressure. In case the setting does not remain stable, check the idle linkage; any looseness in this linkage would cause erratic idling. In all cases, allowance should be made for the effect of weather conditions and field altitude upon idling adjustment.

3. LUBRICATION SYSTEM.

a. Oil Grades and Limitations - Service the engine in accordance with the recommended grade oil as specified in Section 3, item 10.

b. Oil Suction and Oil Pressure Screens - At each twenty-five hour inspection remove, inspect for metal particles, clean and reinstall, not to exceed four (4) months between oil changes.

NOTE

On installations employing full flow oil filters, this step is not practical at this time, but should be observed at the 50 hour inspection, not to exceed four (4) months between oil changes.

TEXTRON LYCOMING OPERATOR'S MANUAL

SECTION 5

O-320 & IO-320 SERIES

c. Oil Relief Valve (Non-Adjustable) - The function of the oil pressure relief valve is to maintain engine oil pressure within specified limits. The valve, although not adjustable, may be controlled by the addition of a maximum of nine STD-425 washers under the cap to increase pressure or the use of a spacer (Textron Lycoming P/N 73629 or 73630) to decrease pressure. A modification on later models has eliminated the need for the spacers. Particles of metal or other foreign matter lodged between the ball and seat will result in faulty readings. It is advisable, therefore, to disassemble, inspect and clean the valve if excessive pressure fluctuations are noted.

d. Oil Relief Valve (Adjustable) - The adjustable oil relief valve enables the operator to maintain engine oil pressure within the specified limits. If the pressure under normal operating conditions should consistently exceed the maximum or minimum specified limits, adjust the valve as follows:

With the engine warmed up and running at approximately 2000 RPM, observe the reading on the oil pressure gage. If the pressure is above maximum or below minimum specified limits, stop engine and screw the adjusting screw out to decrease pressure and in to increase pressure. Depending on installation, the adjusting screw may have only a screw driver slot and is turned with a screw driver; or may have the screw driver slot plus a pinned .375-24 castellated nut and may be turned with either a screw driver or a box wrench.

4. CYLINDERS. Although the complete procedure for disassembly and reassembly is given here, it is recommended that, as a field operation, cylinder maintenance be confined to replacement of the entire assembly. Valve replacement should be undertaken only as an emergency measure.

a. Removal of Cylinder Assembly -

- (1) Remove exhaust manifold.
- (2) Remove rocker box drain tube, intake pipe, baffle and any clips that might interfere with the removal of the cylinder.

- (3) Disconnect ignition cables and remove spark plugs.
- (4) Remove rocker box cover and rotate crankshaft until piston is approximately at top center of the compression stroke. This approximate position may be located by observing top of piston through the spark plug hole and also watching the valve action.
- (5) Slide valve rocker shafts from cylinder head and remove the valve rockers. Valve rocker shafts can be removed when the cylinder is removed from the engine. Remove rotator cap from exhaust valve stem.
- (6) Remove push rods by grasping ball end and pulling rod out of shroud tube. Detach shroud tube spring and lock plate and pull shroud tubes through holes in cylinder head.

NOTE

The hydraulic tappets, push rods, rocker arms and valves must be assembled in the same location from which they were removed.

- (7) Remove cylinder base nuts and hold down plates (where employed) then remove cylinder by pulling directly away from crankcase. Be careful not to allow the piston to drop against the crankcase, as the piston leaves the cylinder.

b. Removal of Valves and Valve Springs from Cylinder - Place the cylinder over a block of wood so as to hold the valves in a closed position. Compress the valve springs using the valve spring compressor. Remove the split keys from the end of the valve stem. The valve springs and valve spring seats may now be removed from the cylinder head. Hold the valve stems so that the valves will not fall out and remove the cylinder from the holding block. The valves may now be removed from the inside of the cylinder.

c. Removal of Piston from Connecting Rod - Remove the piston pin plugs. Insert piston pin puller through piston pin, assemble puller nut; then proceed to remove piston pin. Do not allow connecting rod to rest on the cylinder pad of the crankcase. Support with heavy rubber bands, discarded cylinder base oil ring seals or any other method.

d. Removal of Hydraulic Tappet Sockets and Plunger Assemblies - It will be necessary to remove and bleed the hydraulic tappet plunger assembly so that dry tappet clearance can be checked when the cylinder assembly is reinstalled. This is accomplished in the following manner:

(1) Remove the hydraulic tappet push rod socket by inserting the forefinger into the concave end of the socket and withdrawing. The socket will usually stick to the finger firmly enough to be pulled out of the tappet body. If the socket cannot be removed in this manner, it may be removed by grasping the edge of the socket with a pair of needle nose pliers. However, care must be exercised to avoid scratching the socket.

(2) To remove the hydraulic tappet plunger assembly, use the special Avco Lycoming service tool. In the event that the tool is not available, the hydraulic tappet plunger assembly may be removed by a hook in the end of a short piece of lockwire, inserting the lockwire around the edge of the plunger assembly and turning the wire so that the hook engages the spring of the plunger assembly. Draw the plunger assembly out of the tappet body by gently pulling the wire.

CAUTION

Never use a magnet to remove hydraulic plunger assemblies from the crankcase. This can cause the check ball to remain off its seat, rendering the unit inoperative.

e. Assembly of Hydraulic Tappet Plunger Assemblies - To assemble the unit, unseat the ball by inserting a thin clean bronze wire through the oil inlet hole. With the ball off its seat, insert the plunger and twist clockwise so that the spring catches.

f. Assembly of Valves in Cylinder - Prelubricate valve stems with Molytex Grease O or equivalent and insert each valve stem in its respective valve guide. Place cylinder over a block of wood so that the valves are held against the seats and assemble the lower valve spring seat, auxiliary valve spring and outer valve spring over the valve stem and guide. Place the upper valve spring seat on top of the springs.

NOTE

When installing valve springs, place the dampener end of spring (close wound coils marked with dye or lacquer) toward the cylinder.

Using a valve spring compressor, compress the valve springs and place the split keys in the groove around the upper end of the valve stem. Slowly release the pressure on the valve spring compressor and allow the upper spring seat to lock itself in place around the valve keys.

g. Assembly of Cylinder and Related Parts - Rotate the crankshaft so that the connecting rod of the cylinder being assembled is at the top center position that corresponds with both valves closed.

(1) Place each plunger assembly in its respective tappet body and assemble the socket on top of plunger assembly.

(2) Assemble piston with rings so that the cylinder number stamped on the piston pin boss is toward the front of the engine. The piston pin should be a handpush fit. If difficulty is experienced in inserting the piston pin, it is probably caused by carbon or burrs in the piston pin hole. During assembly, always use a generous quantity of oil, both in the piston pin hole and on the piston pin.

(3) Assemble one piston pin plug at each end of the piston pin and place a new rubber oil seal ring around the cylinder skirt. Coat piston and rings and the inside of the cylinder generously with oil.

(4) Using a piston ring compressor, assemble the cylinder over the piston so that the intake and exhaust ports are at the bottom of the engine. Push the cylinder all of the way on, catching the ring compressor as it is pushed off.

NOTE

Before installing cylinder hold-down nuts, lubricate crankcase through stud threads with any one of the following lubricants, or combination of lubricants.

- 1. 90% SAE 50W engine oil and 10% STP.*
- 2. Parker Thread Lube.*
- 3. 60% SAE 30 engine oil and 40% Parker Thread Lube.*

SECTION 5

O-320 & IO-320 SERIES

(5) Assemble hold-down plates (where applicable) and cylinder base hold-down nuts and tighten as directed in the following steps:

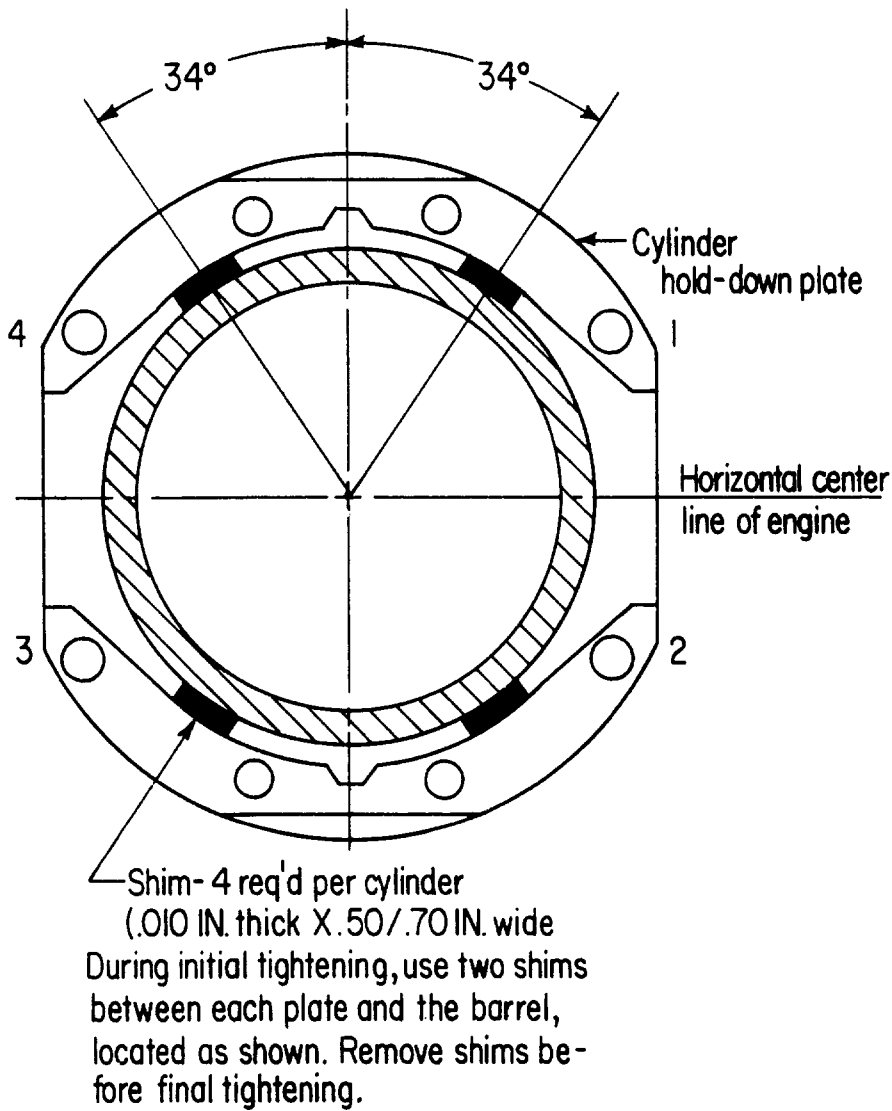

Figure 5-3. Location of Shims Between Cylinder Barrel and Hold-Down Plates (where applicable) and Sequence of Tightening Cylinder Base Hold-Down Nuts

NOTE

At any time a cylinder is replaced, it is necessary to retorque the thru-studs on the cylinder on the opposite side of the engine.

(a) (*Engines using hold-down plates*) Install shims between cylinder base hold-down plates and cylinder barrel, as directed in figure 5-3, and tighten 1/2 inch hold-down nuts to 300 inch lbs. (25 foot lbs.) torque, using the sequence shown in figure 5-3.

(b) Remove shims, and using the same sequence, tighten the 1/2 inch cylinder base nuts, to 600 in. lbs. (50 foot lbs.) torque.

NOTE

Cylinder assemblies not using hold-down plate are tightened in the same manner as above omitting the shims.

(c) Tighten the 3/8 inch hold-down nuts to 300 inch lbs. (25 foot lbs.) torque. Sequence of tightening is optional.

(d) As a final check, hold the torque wrench on each nut for about five seconds. If the nut does not turn, it may be presumed to be tightened to correct torque.

CAUTION

After all cylinder base nuts have been tightened, remove any nicks in the cylinder fins by filing or burring.

(6) Install a new shroud tube oil seal on the crankcase end of each shroud tube and fit a new annular ring in the groove provided in the rocker box and of each shroud tube. Install each shroud tube through rocker box and seat the end firmly in the crankcase. Place a spacer, two springs, a lock plate and nut over the stud provided in the rocker box and secure both shroud tubes in place. Bend the tang of the lock plate to prevent the nut and spring from loosening.

SECTION 5

O-320 & IO-320 SERIES

(7) Assemble each push rod in its respective shroud tube, and assemble each rocker in its respective position by placing rocker between bosses and sliding valve rocker shaft in place to retain rocker. Before installing exhaust valve rocker, place rotator cap over end of exhaust valve stem.

(8) Be sure that the piston is at top center of compression stroke and that both valves are closed. Check clearance between the valve stem tip and the valve rocker. In order to check this clearance, place the thumb of one hand on the valve rocker directly over the end of the push rod and push down so as to compress the hydraulic tappet spring. While holding the spring compressed, the valve clearance should be between .028 and .080 inch. If clearance does not come within these limits, remove the push rod and insert a longer or shorter push rod, as required to correct clearance.

NOTE

Inserting a longer push rod will decrease the valve clearance.

(9) Install intercylinder baffles, rocker box covers, intake pipes, rocker box drain tubes and exhaust manifold.

5. GENERATOR OR ALTERNATOR DRIVE BELT TENSION.

Check the tension of a new belt 25 hours after installation. Refer to Service Instruction No. 1129 and Service Letter No. L160 for methods of checking generator or alternator drive belt tension.

SECTION

6

TROUBLESHOOTING

TROUBLE—SHOOTING

	Page
Failure of Engine to Start6-1
Failure of Engine to Idle Properly6-2
Low Power and Uneven Running6-2
Failure of Engine to Develop Full Power6-3
Rough Engine6-4
Low Oil Pressure6-4
High Oil Temperature6-4
Excessive Oil Consumption6-5

SECTION 6**TROUBLE—SHOOTING**

Experience has proven that the best method of trouble-shooting is to decide on the various causes of a given trouble and then to eliminate causes one by one, beginning with the most probable. The following charts list some of the more common troubles, which may be encountered in maintaining engines; their probable causes and remedies.

1. TROUBLE-SHOOTING—ENGINE.

TROUBLE	PROBABLE CAUSE	REMEDY
Failure of Engine to Start	Lack of fuel	Check fuel system for leaks. Fill fuel tank. Clean dirty lines, strainers or fuel valves.
	Overpriming	Leave ignition "off" and mixture control in "Idle Cut-Off", open throttle and "unload" engine by cranking for a few seconds. Turn ignition switch on and proceed to start in a normal manner.
	Defective spark plugs	Clean and adjust or replace spark plugs.
	Defective ignition wire	Check with electric tester, and replace any defective wires.
	Defective battery	Replace with charged battery.

SECTION 6

O-320 & IO-320 SERIES

TROUBLE	PROBABLE CAUSE	REMEDY
Failure of Engine to Start (Cont.)	Improper operation of magneto breaker	Clean points. Check internal timing of magnetos.
	Lack of sufficient fuel flow	Disconnect fuel line and check fuel flow.
	Water in fuel injector or carb.	Drain fuel injector or carburetor and fuel lines.
Failure of Engine to Idle Properly	Internal failure	Check oil screens for metal particles. If found, complete overhaul of the engine may be indicated.
	Incorrect idle mixture	Adjust mixture.
	Leak in induction system	Tighten all connections in the induction system. Replace any parts that are defective.
	Incorrect idle adjustment	Adjust throttle stop to obtain correct idle.
	Uneven cylinder compression	Check condition of piston rings and valve seats.
	Faulty ignition system	Check entire ignition system.
	Insufficient fuel pressure	Adjust fuel pressure.
Low Power and Uneven Running	Mixture too rich indicated by sluggish operation, red exhaust flame at night. Extreme cases indicated by black smoke from exhaust.	Readjustment of fuel injector or carburetor by authorized personnel is indicated.

AVCO LYCOMING OPERATOR'S MANUAL**O-320 & IO-320 SERIES****SECTION 6**

TROUBLE	PROBABLE CAUSE	REMEDY
Low Power and Uneven Running (Cont.)	Mixture too lean; indicated by overheating or back-firing	Check fuel lines for dirt or other restrictions. Readjustment of fuel injector or carburetor by authorized personnel is indicated.
	Leaks in induction system	Tighten all connections. Replace defective parts.
	Defective spark plugs	Clean and gap or replace spark plugs.
	Improper fuel	Fill tank with fuel of recommended grade.
	Magneto breaker points not working properly	Clean points. Check internal timing of magnetos.
	Defective ignition wire	Check wire with electric tester. Replace defective wire.
Failure of Engine to Develop Full Power	Defective spark plug terminal connectors	Replace connectors on spark plug wire.
	Leak in induction system	Tighten all connections and replace defective parts.
	Throttle lever out of adjustment	Adjust throttle lever.
	Improper fuel flow	Check strainer, gage and flow at the fuel inlet.
	Restriction in air scoop	Examine air scoop and remove restrictions.

LYCOMING OPERATOR'S MANUAL

SECTION 6

O-320 & IO-320 SERIES

TROUBLE	PROBABLE CAUSE	REMEDY
Failure of Engine to Develop Full Power (Cont.)	Improper fuel	Drain and refill tank with recommended fuel.
	Faulty ignition	Tighten all connections. Check system with tester. Check ignition timing.
Rough Engine	Cracked engine mount	Replace or repair mount.
	Defective mounting bushings	Install new mounting bushings.
	Uneven compression	Check compression.
Low Oil Pressure	Insufficient oil	Fill to proper level with recommended oil.
	Air lock or dirt in relief valve	Remove and clean oil pressure relief valve.
	Leak in suction line or pressure line	Check gasket between accessory housing and crankcase.
	High oil temperature	See "High Oil Temperature" in "Trouble" column.
	Defective pressure gage	Replace.
High Oil Temperature	Stoppage in oil pump intake passage	Check line for obstruction. Clean suction strainer.
	Insufficient air cooling	Check air inlet and outlet for deformation or obstruction.

TROUBLE	PROBABLE CAUSE	REMEDY
High Oil Temperature (Cont.)	Insufficient oil supply	Fill to proper level with specified oil.
	Low grade of oil	Replace with oil conforming to specifications.
	Clogged oil lines or strainers	Remove and clean oil strainers.
	Excessive blow-by	Usually caused by worn or stuck rings.
	Failing or failed bearing	Examine sump for metal particles. If found, overhaul of engine is indicated.
Excessive Oil Consumption	Defective temperature gage	Replace gage.
	Low grade of oil	Fill tank with oil conforming to specifications.
	Failing or failed bearings	Check sump for metal particles.
	Worn piston rings	Install new rings.
	Incorrect installation of piston rings	Install new rings.
	Failure of rings to seat (new nitrided cylinders)	Use mineral base oil. Climb to cruise altitude at full power and operate at 75% cruise power setting until oil consumption stabilizes.

SECTION

7

**INSTALLATION AND
STORAGE**

INSTALLATION AND STORAGE

	Page
Preparation of Engine for Installation	7-1
Inspection of Engine Mounting	7-2
Attaching Engine to Mounts	7-2
Oil and Fuel Line Connections	7-2
Propeller Installation	7-2
Preparation of Carburetors and Fuel Injectors for Installation	7-2
Preparation of Engine for Storage or Shipment	7-3
General	7-3
Preservation Run	7-3
Fuel	7-3
Oil	7-3
Duration of Run	7-3
Compound Injection	7-3
Installation of Seals and Plugs	7-4
Exterior Surfaces	7-4
Carburetor	7-4
Fuel Injector	7-4
Recommended Procedure for Re-Preservation	7-5

SECTION 7**INSTALLATION AND STORAGE**

1. PREPARATION OF ENGINE FOR INSTALLATION. Before installing an engine that has been prepared for storage, remove all dehydrator plugs, bags of dessicant and preservative oil from the engine. Preservative oil can be removed by removing the bottom spark plugs and turning the crankshaft three or four revolutions by hand. The preservative oil will then drain through the spark plug holes. Draining will be facilitated if the engine is tilted from side to side during the above operation. Preservative oil which has accumulated in the sump can be drained by removing the oil sump plug. Engines that have been stored in a cold place should be removed to an environment of at least 70°F. (21°C.) for a period of 24 hours before preservative oil is drained from the cylinders. If this is not possible, heat the cylinders with heat lamps before attempting to drain the engine.

After the oil sump has been drained, the plug should be replaced and safety-wired. Fill the sump with lubricating oil. The crankshaft should again be turned several revolutions to saturate the interior of the engine with the clean oil. When installing spark plugs, make sure that they are clean, if not, wash them in clean petroleum solvent. Of course, there will be a small amount of preservative oil remaining in the engine, but this can cause no harm. However, after twenty-five hours of operation, the lubricating oil should be drained while the engine is hot. This will remove any residual preservative oil that may have been present.

CAUTION

Do not rotate the crankshaft of an engine containing preservative oil before removing the spark plugs, because if the cylinders contain any appreciable amount of the mixture, the resulting action, known as hydraulic, will cause damage to the engine. Also, any contact of the preservative oil with painted surfaces should be avoided.

General - Should any of the dehydrator plugs, containing crystals of silica-gel or similar material, be broken during their term of storage or upon their removal from the engine, and if any of the contents should fall into the engine, that portion of the engine must be disassembled and thoroughly cleaned before using the engine. The oil strainers should be removed and cleaned in gasoline or some other hydrocarbon solvent. The fuel drain screen located in the fuel inlet of the carburetor or fuel injector should also be removed and cleaned in a hydrocarbon solvent. The operator should also note if any valves are sticking. If they are, this condition can be eliminated by coating the valve stem generously with a mixture of gasoline and lubricating oil.

Inspection of Engine Mounting - If the aircraft is one from which an engine has been removed, make sure that the engine mount is not bent or damaged by distortion or misalignment as this can produce abnormal stresses within the engine.

Attaching Engine to Mounts - See airframe manufacturer's recommendations for method of mounting the engine.

Oil and Fuel Line Connections - The oil and fuel line connections are called out on the accompanying installation drawings.

Propeller Installation - Consult the airframe manufacturer for information relative to propeller installation.

2. PREPARATION OF CARBURETORS AND FUEL INJECTORS FOR INSTALLATION.

Carburetors and fuel injectors that have been prepared for storage should undergo the following procedures before being placed in service.

Carburetor - Remove the fuel drain plug and drain preservative oil. Remove the fuel inlet strainer assembly and clean in a hydrocarbon solvent. Reinstall the fuel drain plug and fuel inlet strainer assembly.

Fuel Injector - Remove and clean the fuel inlet strainer assembly and reinstall. Inject clean fuel into the fuel inlet connection with the fuel outlets uncapped until clean fuel flows from the outlets. Do not exceed 15 psi inlet pressure.

3. PREPARATION OF ENGINE FOR STORAGE OR SHIPMENT.

General - The following procedure is intended for application to installed engines, which are being removed from aircraft and will provide protection from corrosion for a period of 30 to 60 days.

Preservation Run - Immediately prior to removal of the engine from the aircraft, the engine should be given a preservation run under the following operating conditions.

Fuel - Normal service fuel.

Oil - Fill sump to normal capacity with preservative type lubricating oil (Soconoy's Avrex 901, Esso's "Rust-Ban 626" or equivalent).

Duration of Run - Operate the engine for a period of four minutes, holding the engine speed to a maximum of 1800 RPM. All precautions pertaining to ground running should be carefully observed. Cylinder head, ignition harness, and magneto temperatures should not be allowed to exceed the prescribed limits.

Compound Injection - Upon completion of the preservation run, drain the preservative oil from the engine and remove, clean and replace the oil suction and oil pressure screens. Perform any of the engine checks, such as valve clearance or ignition timing, which require rotation of the crankshaft. Disconnect the ignition harness and remove the spark plugs. Starting with cylinder No. 1, make certain piston is at the bottom of compression stroke. Fill cylinder with preservative oil (use same oil as specified for preservation run) and rotate crankshaft until piston is at top center. Oil will spill out of spark plug hole. In order to preserve the top wall of the cylinder, it will be necessary to either rock the engine, or blow compressed air with very light pressure into the spark plug hole. Following the engine firing order, preserve the remainder of the cylinders in the same manner. When all cylinders have been treated, then spray the exhaust port and valve of each cylinder with the piston 1/4 turn before top center on the exhaust stroke. When absolutely certain that no further need exists for turning the crankshaft, again spray each cylinder through the spark plug holes. (Maintain spray nozzle temperature at 200°F. to 220°F. (93°C. to 104°C.) for all spraying operations.)

SECTION 7**O-320 & IO-320 SERIES**

Installation of Seals and Plugs - Install cylinder dehydrator plugs (Avco Lycoming P/N 40238 or equivalent) in spark plug holes. Install ignition cable protectors (Avco Lycoming P/N 40239 or equivalent) over the spark terminal of each ignition cable and secure by attaching to the end of the dehydrator plug. Flush all accessory drives for which oil seals are provided with preservative oil before assembling the drive covers. Suitable covers should be used in sealing the exhaust ports; moisture resistant tape (Minnesota Mining and Manufacturing Company, 711 Acetate Fibre Tape or equivalent) will be sufficient for the ground connections and similar openings. Install a plug (Avco Lycoming P/N 1540 or equivalent) in the thermometer well at the rear of the oil pressure screen housing. Install sealing caps (Avco Lycoming P/N 61595 or equivalent) over the breather opening and (Avco Lycoming P/N 61596 or equivalent) over the generator or alternator blast tube. Install tachometer drive cap (Avco Lycoming P/N 61545 or equivalent) over tachometer drive. Make sure all other openings are properly sealed.

Exterior Surfaces - All exposed cadmium plated and machined surfaces should be coated with soft-film corrosion-preventative compound (E. F. Houghton and Company, Cosmoline 1059 or equivalent). The starter ring gear and propeller mounting surfaces in particular should receive a liberal coating of the compound.

Carburetor - Drain all residual gasoline from the carburetor, fill with flushing oil (MIL-C-16173, Grade 2) and flush the interior surfaces by rocking the carburetor. Drain excess oil from the fuel passages and replace plugs. Lock the throttle in the closed position and pack the carburetor in a cardboard container.

Fuel Injector - Any unit taken out of service, or units being returned for overhaul, must be flushed with preserving oil (Specification MIL-O-6081, Grade 1010), using the following procedure.

Remove plugs and drain all fuel from the injector. If available, apply 10 to 15 psi air pressure to the fuel inlet, until all fuel is discharged from the injector.

Replace plugs and apply flushing oil filtered through a 10 micron filter at 13 to 15 psi to the fuel inlet until oil is discharged from the servo line.

Replace fuel inlet plug.

AVCO LYCOMING OPERATOR'S MANUAL

O-320 & IO-320 SERIES

SECTION 7

CAUTION

Do not exceed the recommended air pressure as internal damage to the injector may result.

After filling with preservative oil the injector should be protected from dust and dirt, and given such protection against moisture as climatic conditions at the point of storage require.

The injector shall be tagged as follows: The fuel chambers and passages of this fuel injector were preserved with oil conforming to Specification MIL-O-6081, Grade 1010. Before using de-preserve in accordance with instructions in operator's manual.

Shipping Case - Upon completion of the preceding steps, the engine should be secured in a suitable engine shipping container. The date of preservation and the following legend should be legibly marked on the side of the container:

"On (Date) the engine was preserved for 60 days short term storage with preservative oil and cylinder and crankcase dehydrator plugs shall be inspected on arrival at destination or 30 days after the above date (whichever occurs sooner) to determine if renewal of the dehydrating agent is necessary."

4. RECOMMENDED PROCEDURE FOR RE-PRESERVATION. The engine shall be examined every 30 days (or less, depending on weather and locality). If any evidence of corrosion is present, the affected area should be cleaned free of corrosion and the engine re-preserved.

Engines prepared in the preceding manner are not adequately protected for extended periods of storage. If at the end of 60 days, it is found that the engine must remain in storage for an additional period, the engine must be re-preserved according to the foregoing procedure.

NOTE

Inspection and re-preservation will not be the responsibility of the engine manufacturer after engines have been shipped from the engine manufacturer's plant. It shall be the responsibility of the consignee to put engines into service in the order of storage preparation date to reduce the storage period to a minimum.

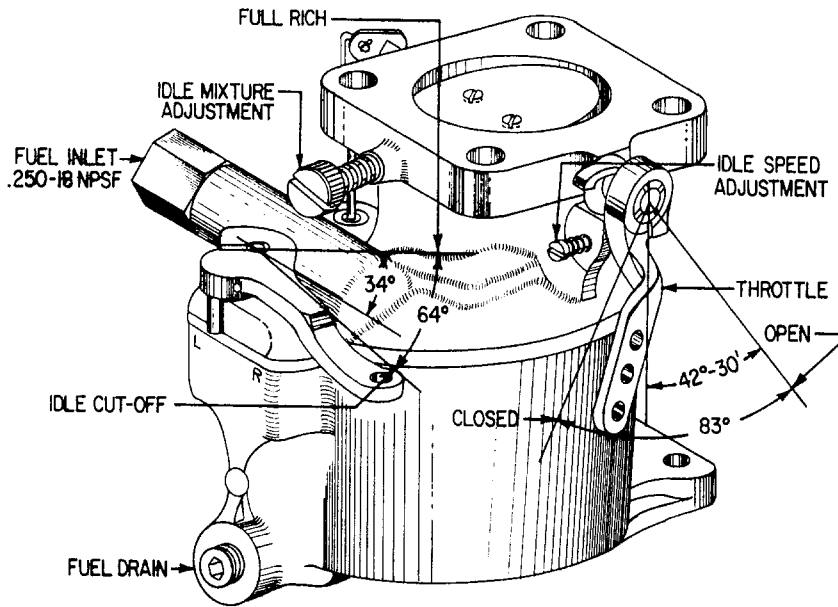

CARBURETOR - MA-4SPA

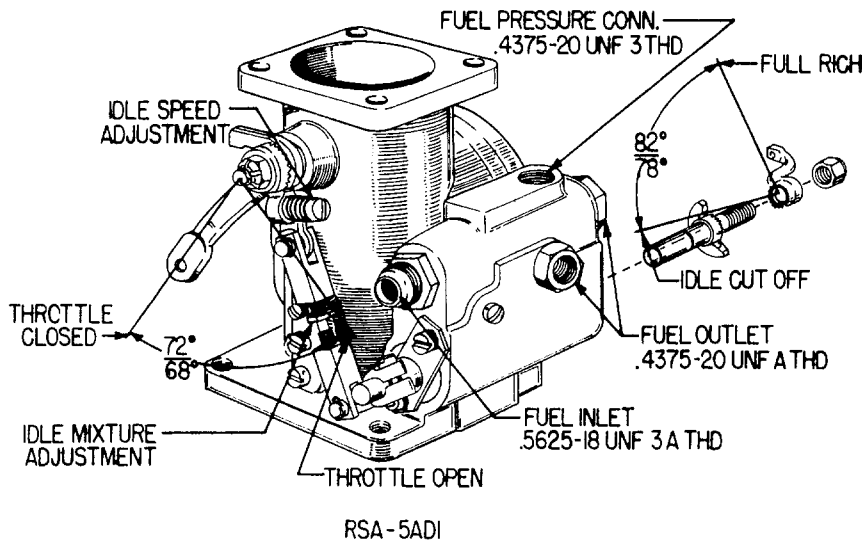

FUEL INJECTOR - RSA-5AD1

Figure 7-1. Fuel Metering Systems

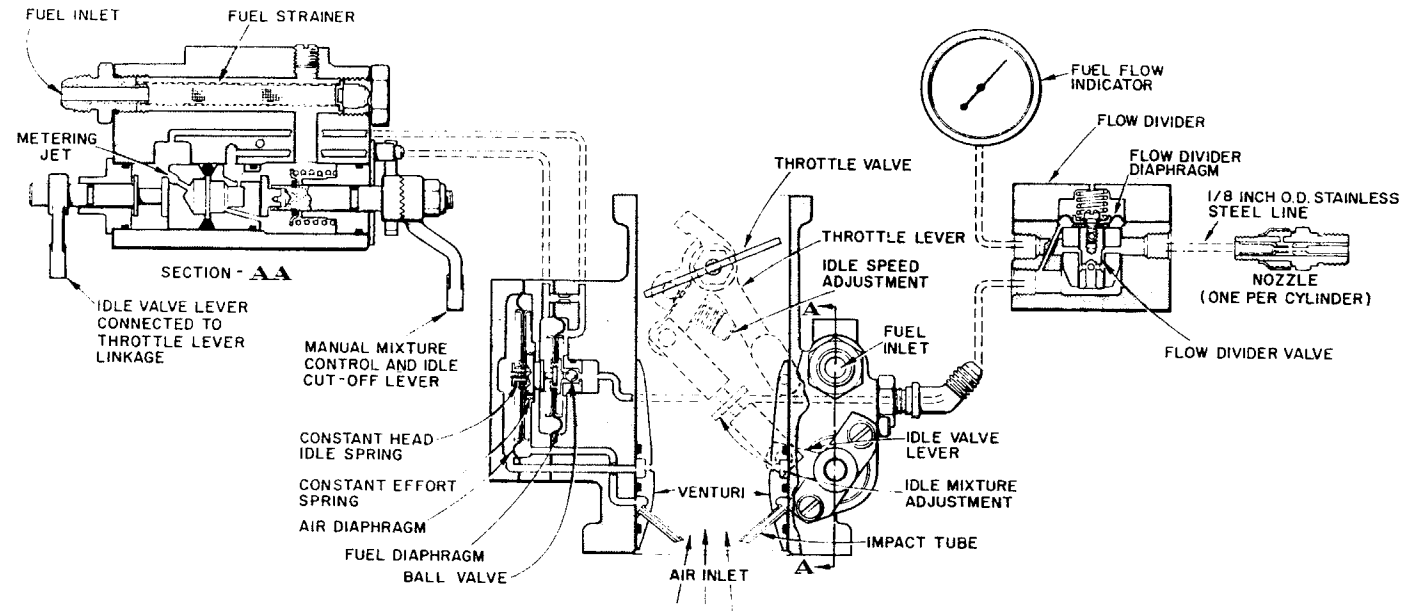

Figure 7-2. Fuel Injector System - RS5AD1

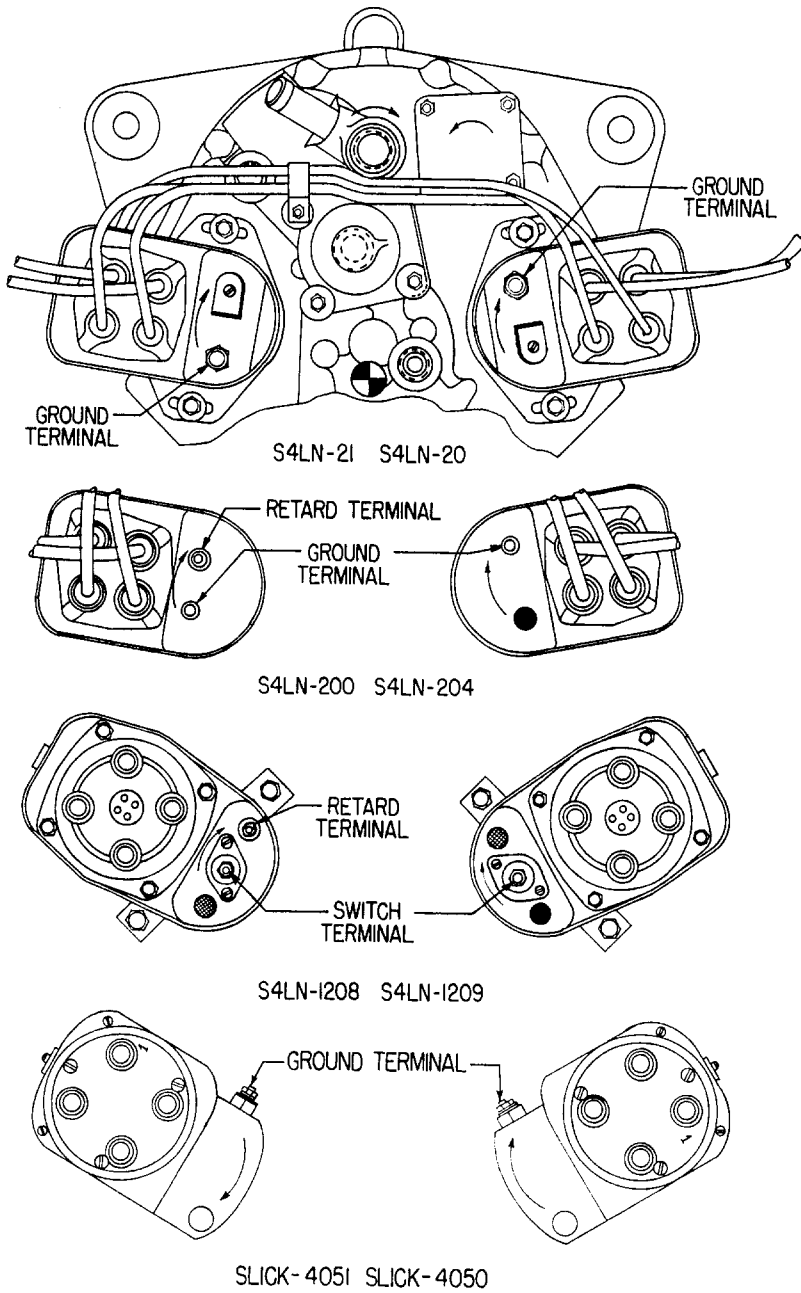

Figure 7-3. Magneto Connections

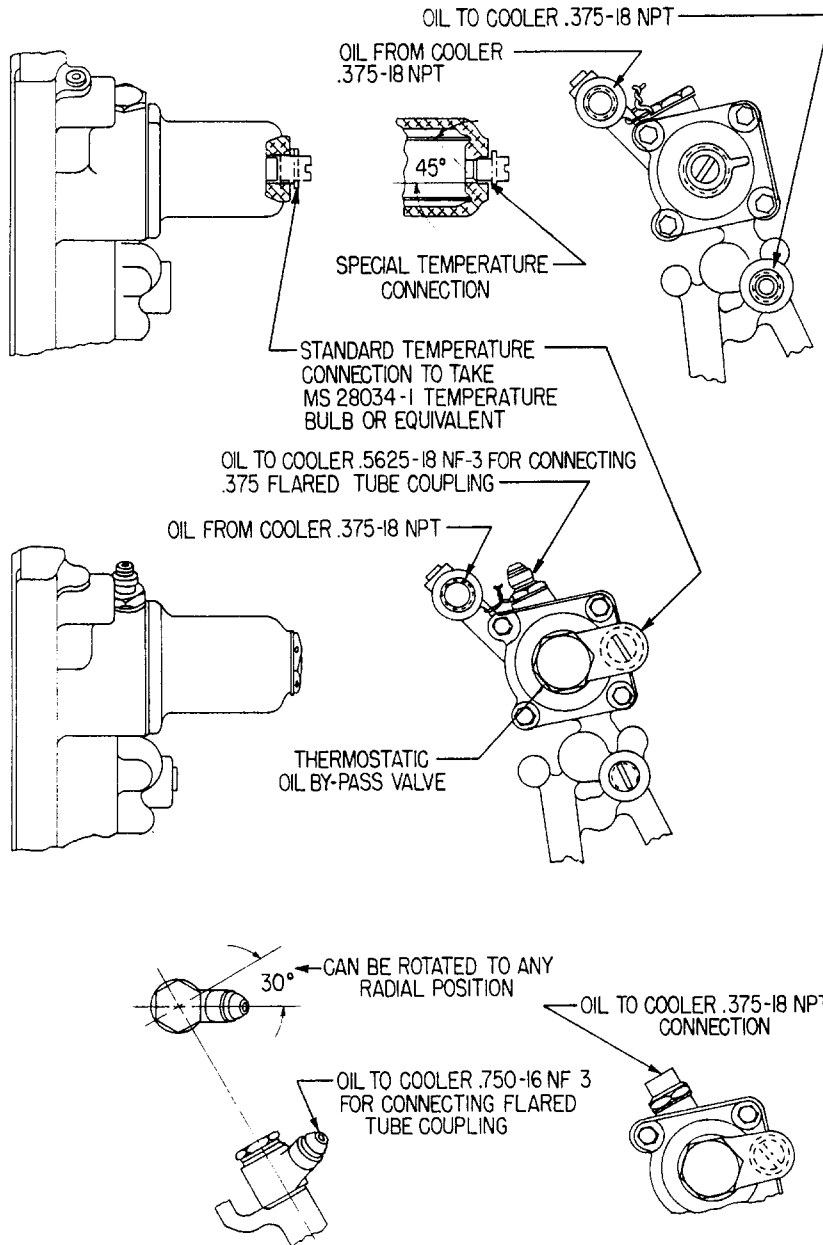

Figure 7-4. Optional Oil Cooler Connections

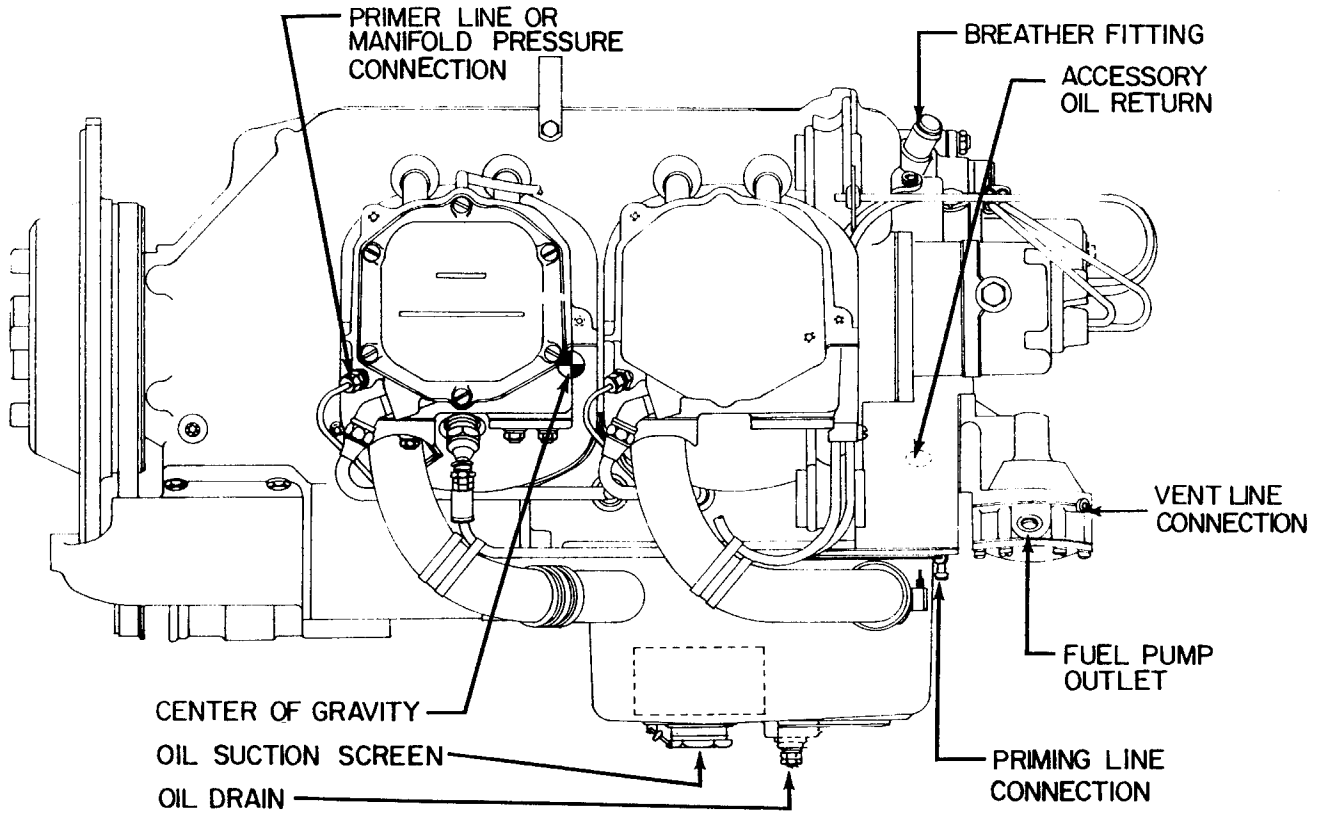

Figure 7-5. Installation Drawing Left Side View - Typical O-320-A, -B Series

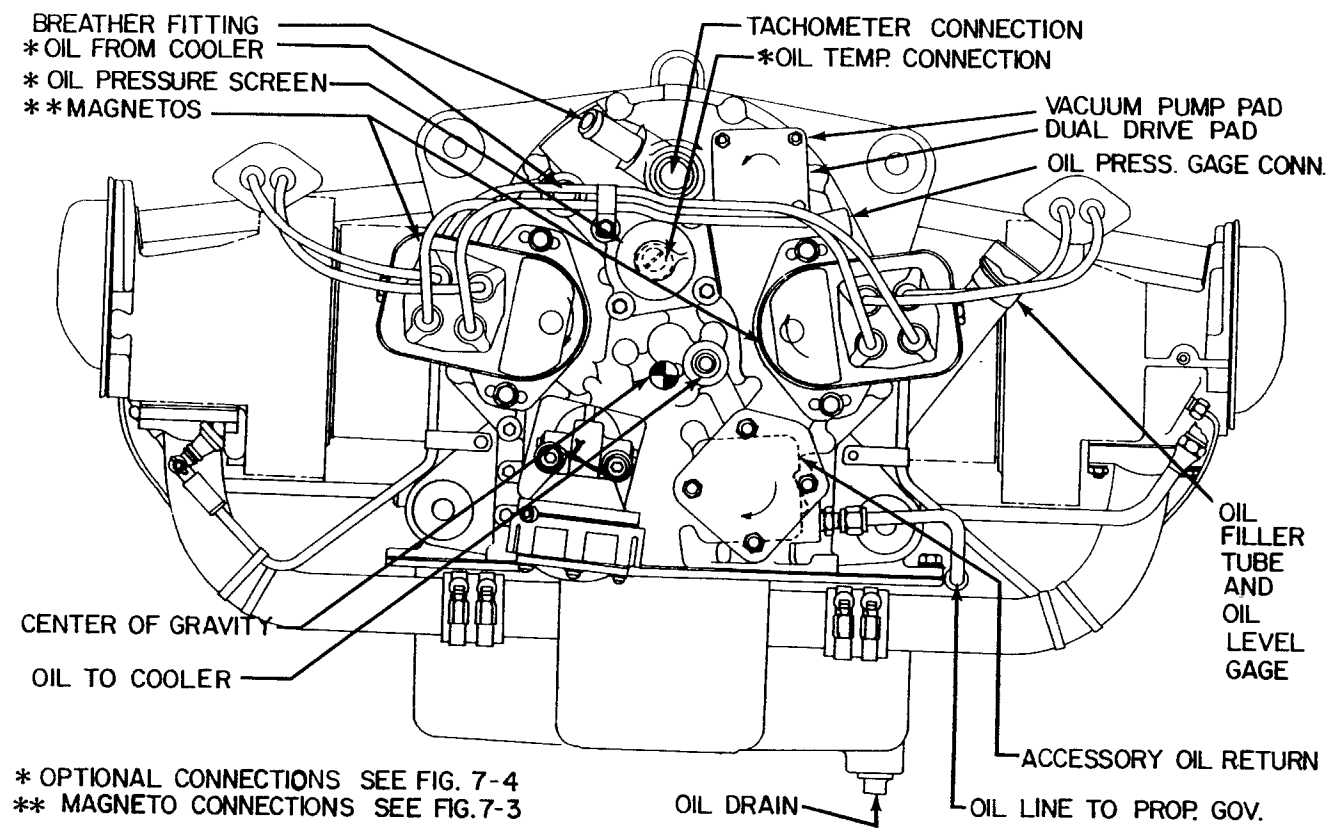

Figure 7-6. Installation Drawing Rear View - Typical O-320-A, -B Series

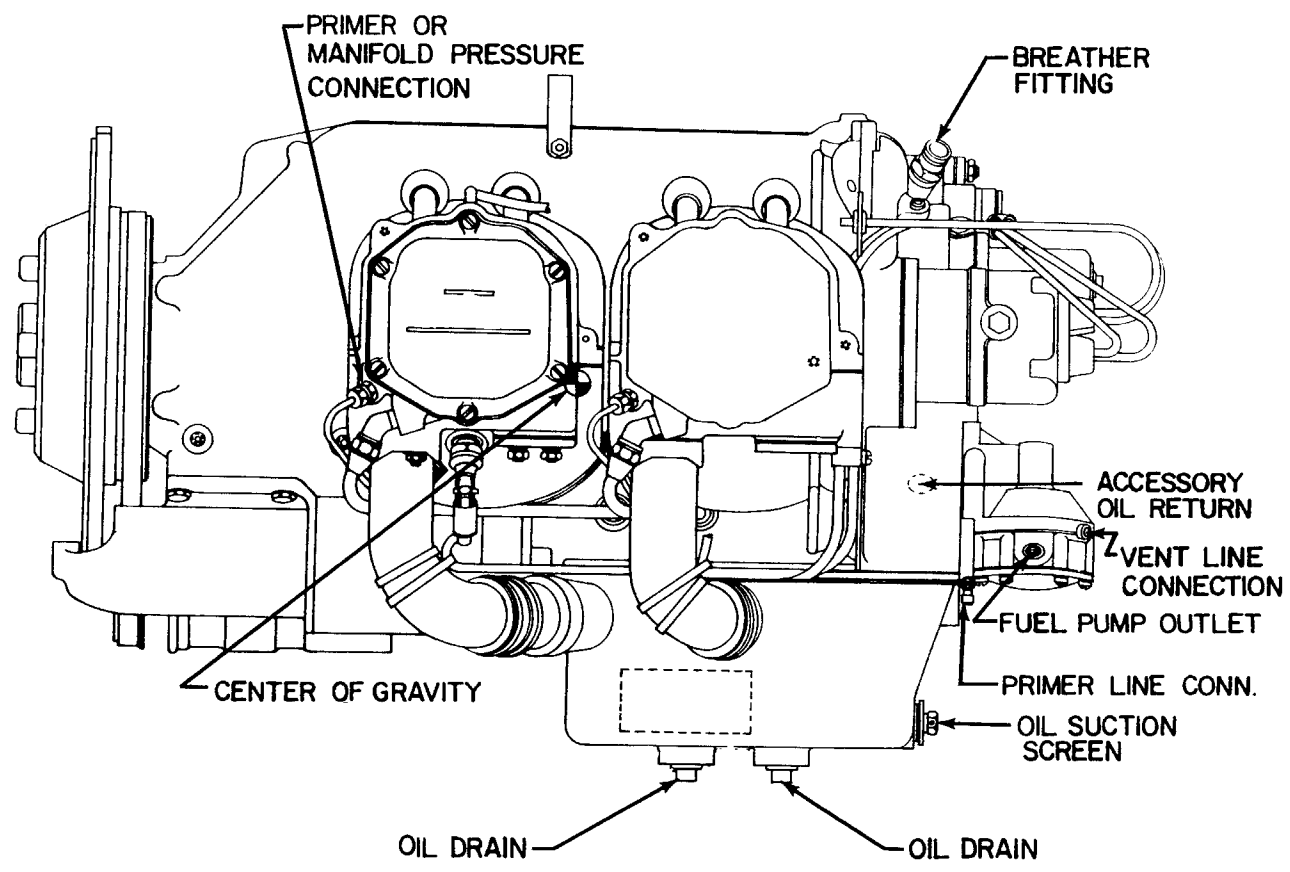

Figure 7-7. Installation Drawing Left Side View - Typical O-320-D, -E Series

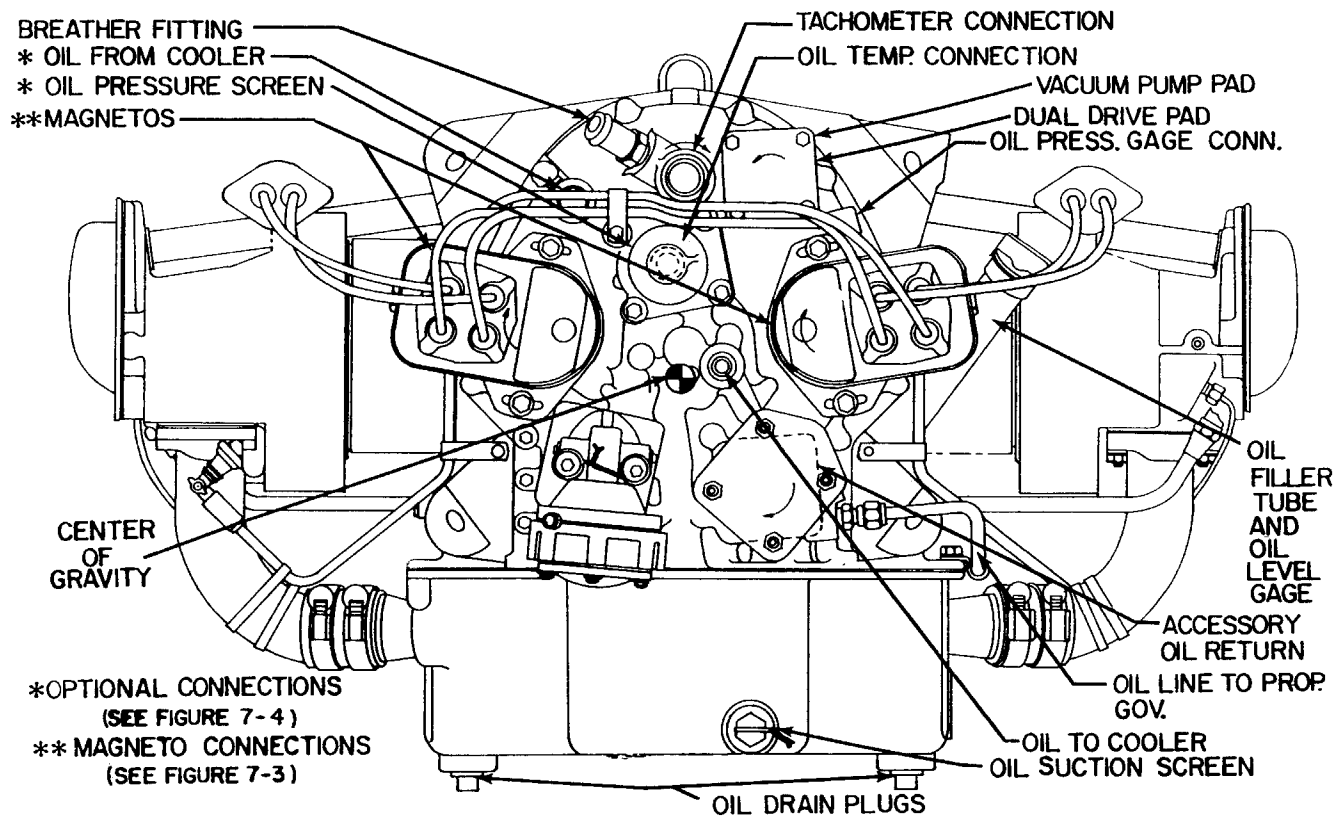

Figure 7-8. Installation Drawing Rear View - Typical O-320-D, -E Series

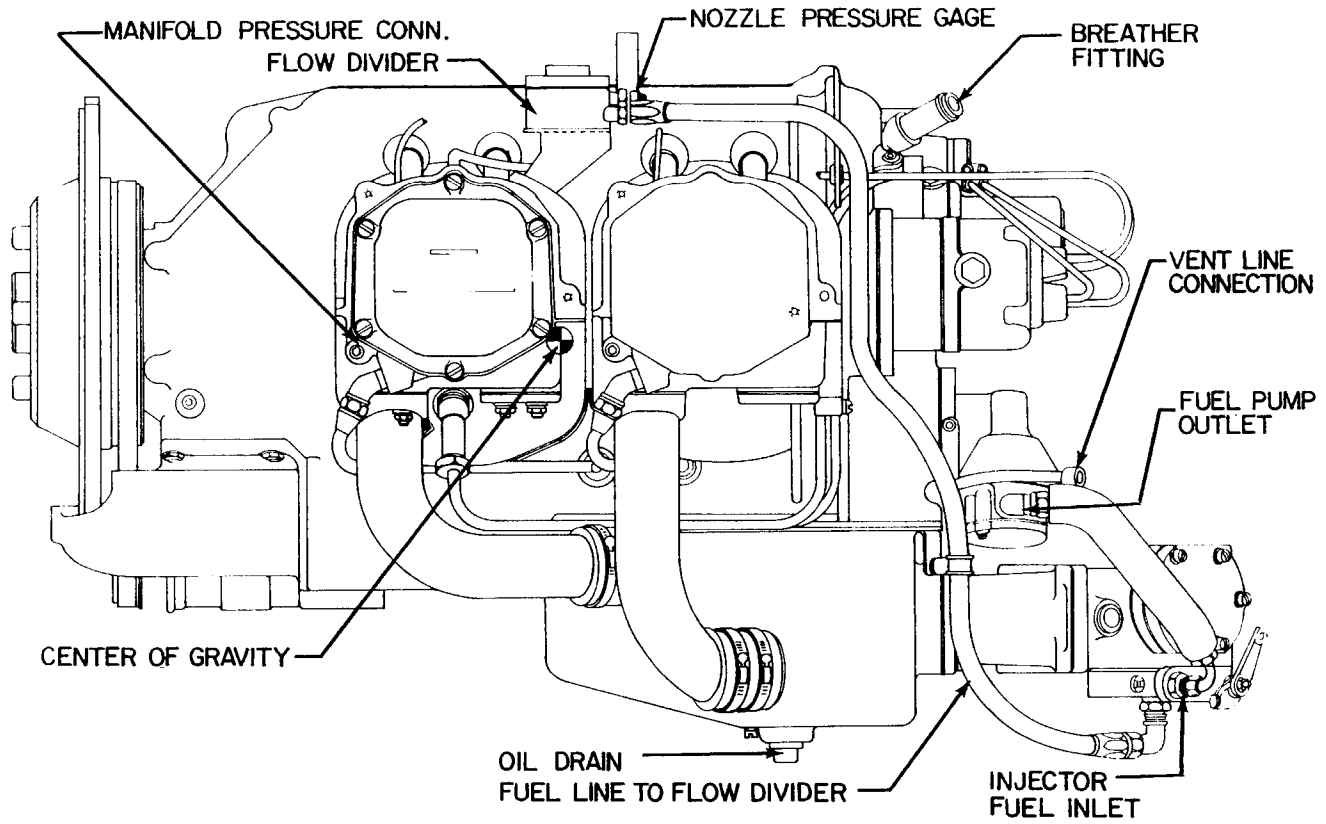

Figure 7-9. Installation Drawing Left Side View - Typical IO-320-B Series

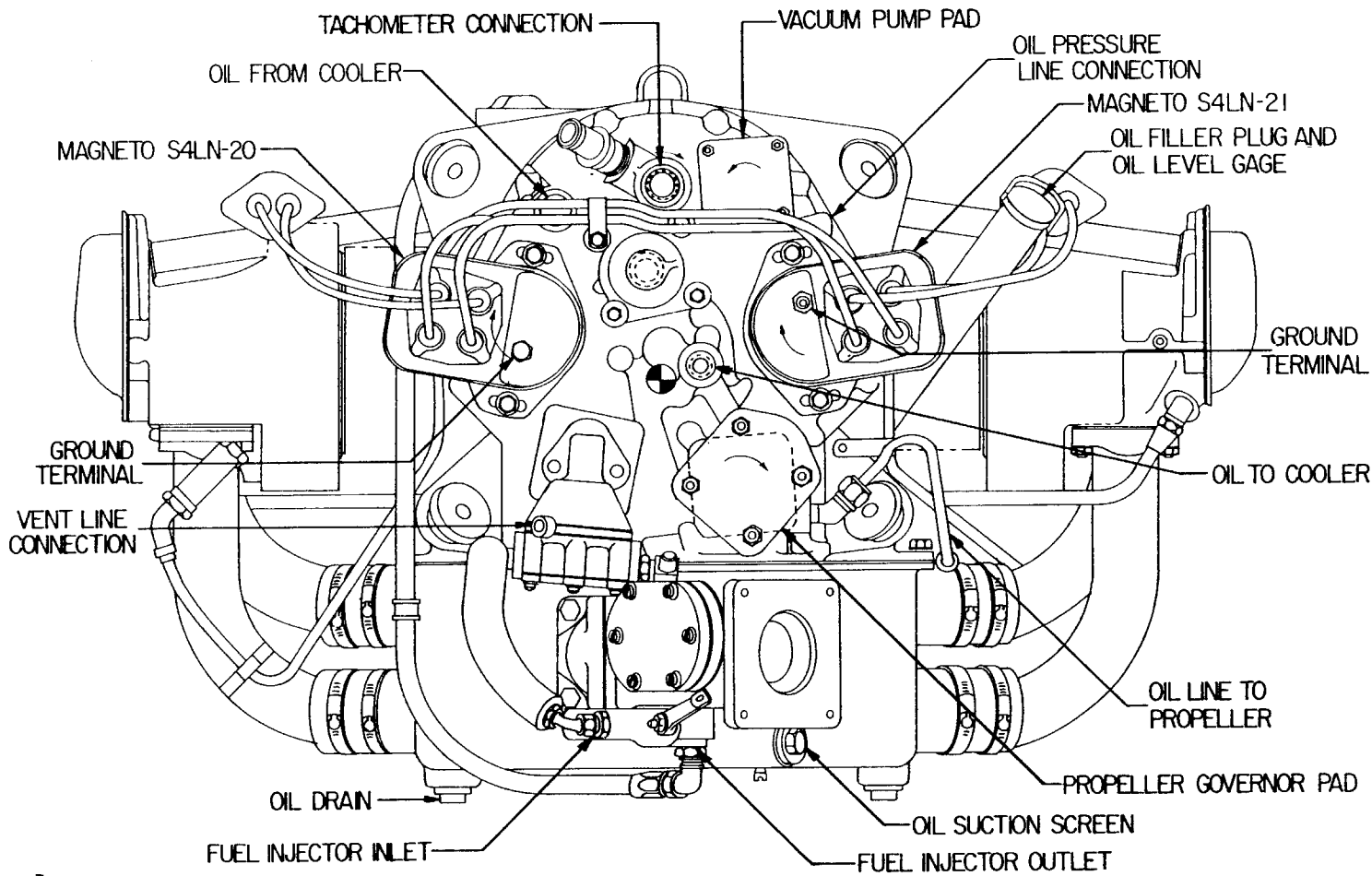

Figure 7-10. Installation Drawing Rear View - Typical IO-320-B Series

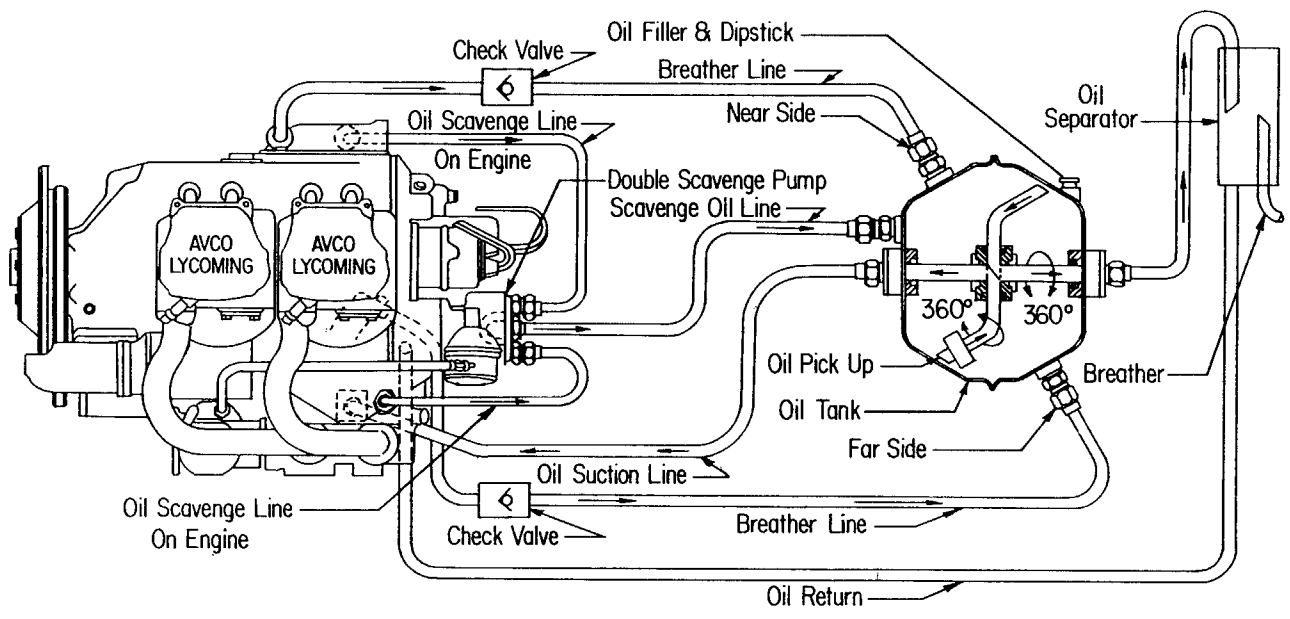

Figure 7-11. Oil System Schematic - AIO-320 Series

SECTION

8

TABLES

TABLES

	Page
Table of Limits8-1
Ground Run After Top Overhaul8-2
Flight Test After Top Overhaul8-3
Full Throttle HP at Altitude8-4
Table of Speed Equivalents8-4
Centigrade-Fahrenheit Conversion Table8-5
Inch - Fraction Conversions8-6

SECTION 8

TABLES

FOR TIGHTENING TORQUE RECOMMENDATIONS AND INFORMATION CONCERNING TOLERANCES AND DIMENSIONS THAT MUST BE MAINTAINED IN AVCO LYCOMING AIRCRAFT ENGINES, CONSULT LATEST EDITION OF SPECIAL SERVICE PUBLICATION NO. SSP2070.

CONSULT LATEST EDITION OF SERVICE INSTRUCTION NO. 1029 AND NO. 1150 FOR INFORMATION PERTINENT TO CORRECTLY INSTALLING CYLINDER ASSEMBLY.

FIXED WING ONLY

**GROUND RUN AFTER TOP OVERHAUL
OR CYLINDER CHANGE WITH NEW RINGS**

(DO NOT USE AFTER MAJOR OVERHAUL)

1. Avoid dusty location and loose stones.
2. Head aircraft into wind.
3. All cowling should be in place, cowl flaps open.
4. Accomplish ground run in full flat pitch.
5. Never exceed 200°F. oil temperature.
6. If cylinder head temperatures reach 400°F., shut down and allow engine to cool before continuing.

Type Aircraft _____

Registration No. _____

Aircraft No. _____

Owner _____

Engine Model _____ S/N _____

Date _____

Run-Up By _____

GROUND RUN

Time	RPM	MAP	Temperature				Pressure				Temperature			Fuel Flow	
			L.oil	R.oil	L.cyl	R.cyl	L.oil	R.oil	L.fuel	R.fuel	L.carb	R.carb	Amb.Air	Left	Right
5 min	1000														
10 min	1200														
10 min	1300														
5 min	1500														
5 min	1600														
5 min	1700														
5 min	1800														

Mag. Check	Adjustment Required	After Completion of Ground Run
Power Check		1. Visually inspect engine(s)
Idle Check		2. Check oil level(s)

FLIGHT TEST AFTER TOP OVERHAUL OR CYLINDER CHANGE WITH NEW RINGS

1. Test fly aircraft one hour.
2. Use standard power for climb, and at least 75% power for cruise.
3. Make climb shallow and at good airspeed for cooling.
4. Record engine instrument readings during climb and cruise.

Tested by _____

FLIGHT TEST RECORD

Time	RPM	MAP	Temperature				Pressure				Temperature			Fuel Flow		
			L.oil	R.oil	L.cyl	R.cyl	L.oil	R.oil	L.fuel	R.fuel	L.carb	R.carb	Amb. Air	Left	Right	
(Climb)																
Cruise																

Adjustments Required After Flight

After Test Flight

1. Make careful visual inspection of engine(s).
2. Check oil level(s).
3. If oil consumption is excessive, (see operator's manual for limits), remove spark plugs and check cylinder barrels for scoring.

FULL THROTTLE HP AT ALTITUDE
(Normally Aspirated Engines)

Altitude Ft.	% S. L. H. P.	Altitude Ft.	% S. L. H. P.	Altitude Ft.	% S. L. H. P.
0	100	10,000	70.8	19,500	49.1
500	98.5	11,000	68.3	20,000	48.0
1,000	96.8	12,000	65.8	20,500	47.6
2,000	93.6	13,000	63.4	21,000	46.0
2,500	92.0	14,000	61.0	21,500	45.2
3,000	90.5	15,000	58.7	22,000	44.0
4,000	87.5	16,000	56.5	22,500	43.3
5,000	84.6	17,000	54.3	23,000	42.2
6,000	81.7	17,500	53.1	23,500	41.4
7,000	78.9	18,000	52.1	24,000	40.3
8,000	76.2	18,500	51.4	24,500	39.5
9,000	73.5	19,000	50.0	25,000	38.5

TABLE OF SPEED EQUIVALENTS

Sec./Mi.	M. P. H.	Sec./Mi.	M. P. H.	Sec./Mi.	M. P. H.
72.0	50	24.0	150	14.4	250
60.0	60	22.5	160	13.8	260
51.4	70	21.2	170	13.3	270
45.0	80	20.0	180	12.8	280
40.0	90	18.9	190	12.4	290
36.0	100	18.0	200	12.0	300
32.7	110	17.1	210	11.6	310
30.0	120	16.4	220	11.2	320
27.7	130	15.6	230	10.9	330
25.7	140	15.0	240	10.6	340

CENTIGRADE-FAHRENHEIT CONVERSION TABLE

Example: To convert 20°C. to Fahrenheit, find 20 in the center column headed (F-C); then read 68.0°F. in the column (F) to the right. To convert 20°F. to Centigrade; find 20 in the center column and read -6.67°C. in the (C) column to the left.

C	F-C	F	C	F-C	F
-56.7	-70	-94.0	104.44	220	428.0
-51.1	-60	-76.0	110.00	230	446.0
-45.6	-50	-58.0	115.56	240	464.0
-40.0	-40	-40.0	121.11	250	482.0
-34.0	-30	-22.0	126.67	260	500.0
-28.9	-20	-4.0	132.22	270	518.0
-23.3	-10	14.0	137.78	280	536.0
-17.8	0	32.0	143.33	290	554.0
-12.22	10	50.0	148.89	300	572.0
-6.67	20	68.0	154.44	310	590.0
-1.11	30	86.0	160.00	320	608.0
4.44	40	104.0	165.56	330	626.0
10.00	50	122.0	171.11	340	644.0
15.56	60	140.0	176.67	350	662.0
21.11	70	158.0	182.22	360	680.0
26.67	80	176.0	187.78	370	698.0
32.22	90	194.0	193.33	380	716.0
37.78	100	212.0	198.89	390	734.0
43.33	110	230.0	204.44	400	752.0
48.89	120	248.0	210.00	410	770.0
54.44	130	266.0	215.56	420	788.0
60.00	140	284.0	221.11	430	806.0
65.56	150	302.0	226.67	440	824.0
71.00	160	320.0	232.22	450	842.0
76.67	170	338.0	237.70	460	860.0
82.22	180	356.0	243.33	470	878.0
87.78	190	374.0	248.89	480	896.0
93.33	200	392.0	254.44	490	914.0
98.89	210	410.0	260.00	500	932.0

INCH FRACTIONS CONVERSIONS
Decimals, Area of Circles and Millimeters

Inch Fraction	Decimal Equiv.	Area Sq. In.	MM Equiv.	Inch Fraction	Decimal Equiv.	Area Sq. In.	MM Equiv.
1/64	.0156	.0002	.397	1/2	.5	.1964	12.700
1/32	.0312	.0008	.794	17/32	.5312	.2217	13.494
3/64	.0469	.0017	1.191	35/64	.5469	.2349	13.891
1/16	.0625	.0031	1.587	9/16	.5625	.2485	14.288
3/32	.0937	.0069	2.381	19/32	.5937	.2769	15.081
7/64	.1094	.0094	2.778	39/64	.6094	.2916	15.478
1/8	.125	.0123	3.175	5/8	.625	.3068	15.875
5/32	.1562	.0192	3.969	21/32	.6562	.3382	16.669
11/64	.1719	.0232	4.366	43/64	.6719	.3545	17.065
3/16	.1875	.0276	4.762	11/16	.6875	.3712	17.462
7/32	.2187	.0376	5.556	23/32	.7187	.4057	18.256
15/64	.2344	.0431	5.593	47/64	.7344	.4235	18.653
1/4	.25	.0491	6.350	3/4	.75	.4418	19.050
9/32	.2812	.0621	7.144	25/32	.7812	.4794	19.844
19/64	.2969	.0692	7.540	51/64	.7969	.4987	20.241
5/16	.3125	.0767	7.937	13/16	.8125	.5185	20.637
11/32	.3437	.0928	8.731	27/32	.8437	.5591	21.431
23/64	.3594	.1014	9.128	55/64	.8594	.5800	21.828
3/8	.375	.1105	9.525	7/8	.875	.6013	22.225
13/32	.4062	.1296	10.319	29/32	.9062	.6450	23.019
27/64	.4219	.1398	10.716	59/64	.9219	.6675	23.416
7/16	.4375	.1503	11.112	15/16	.9375	.6903	23.812
15/32	.4687	.1725	11.906	31/32	.9687	.7371	24.606
31/64	.4844	.1842	12.303	63/64	.9844	.7610	25.003